

General Aptitude Part

Q.1 to Q.5 Carry One Mark Each

Question 1

He did not manage to fix the car himself, so he _____ in the garage.

- (A) got it fixed (B) getting it fixed
(C) gets fixed (D) got fixed

Ans. (A)

Sol. Given :

He did not manage to fix the car himself, so he got it fixed in the garage.

Hence, the correct option is (A).

Question 2

Planting : Seed :: Raising : ?

- (A) Child (B) Temperature
(C) Height (D) Lift

Ans. (A)

Sol. Given :

Planting is related to seeding specific manner putting seeds into the soil and taking care of them so that they can grow. In the same way raising is related to child raising a child by taking care of him/her can be related as raising.

Hence, the correct option is (A).

Question 3

A certain country has 504 universities of 25951 colleges. These are categorized into grade 1, 2, 3 as shown in the given pie charts. What is the percentage, correct to one decimal place, of higher education institutions (colleges and universities) that fall into Grade III?

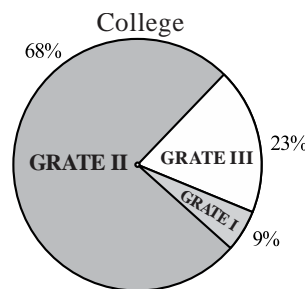
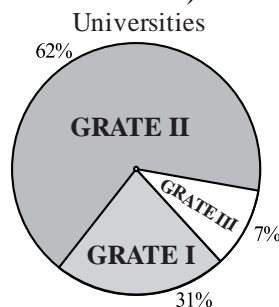

- (A) 22.7 (B) 23.7
(C) 15.0 (D) 66.8

Ans. (A)

Sol. Given :

Universities $U = 504$

Collages $C = 25951$

Total $(U + C) = 504 + 25951 = 26455$

For grade 3 collage and university

$$G_3(U) = \frac{7}{100} \times 504 = 35.28$$

$$G_3(C) = \frac{23}{100} \times 2595 = 5968.73$$

$$G_3(U + C) = 35.28 + 5968.73 = 6004.01$$

$$\text{Now, required \%} = \frac{6004.01}{26455} \times 100 = 22.7\%$$

Hence, the correct option is (A).

Question 4

The minute-hand and second hand of clock cross each other _____ times between 9:15 AM to 9:45 AM on a day.

- (A) 30 (B) 15
(C) 29 (D) 31

Ans. (A)

Sol. The minute hand and second hand of a clock a cross each other one time in every minute but in one hour (60 minute) minute hand and second hand crosses each other only for 59 times.

For an example, in between 9:00 to 10:00 in one hours they will cross each other for 59 times.

The time period in which minute hand and second hand does not cross each other is from 9:00 to 9:01.

As at 9:00 minute hand and second hand are already coincided and when second hand starts rotating it will not be coincide with hour hand till 9:01.

The given time period is from 9:15 am to 9:45 am total minutes are 30.

In these 30 minutes, minute hand and second hand will cross each other for 30 times.

Hence, the correct option is (A).

Question 5

The symbol \circ \star \triangle \square are to be filled one in each box, as shown below.

The rule for filling in the 4 symbols are as follows.

- Every row and every column must contain each of the 4 symbols.
- Every 2×2 square delineated by bold lines must contains each of the 4 symbols.

Which symbol will occupy the box marked with '?' in the partially filled figure?

	?		\triangle
	\circ	\star	
		\square	\star
\star		\triangle	\circ

- (A) \circ (B) \star
(C) \triangle (D) \square

Ans. (B)

Sol. Given :

The rules for filling in the four symbols : \circ , \star , \triangle and \square are as follows :

1. Every row and every column must contain each of the 4 symbols.
2. Every 2×2 square delineated by bold lines must contains each of the 4 symbols.

In the given figure there are 4 rows R_1, R_2, R_3, R_4 and 4 columns are C_1, C_2, C_3 and C_4 .

	C_1	C_2	C_3	C_4
R_1		?		\triangle
R_2		\circ	\star	
R_3			\square	\star
R_4	\star		\triangle	\circ

In the row R_4 symbol \square will be placed in free space and in column C_4 symbol \square will be placed in free space.

	C_1	C_2	C_3	C_4
R_1		?		\triangle
R_2		\circ	\star	\square
R_3			\square	\star
R_4	\star	\square	\triangle	\circ

Now, in column C_3 we can place symbol \circ in free space and in row R_2 \triangle can be placed.

	C_1	C_2	C_3	C_4
R_1		?	\circ	\triangle
R_2	\triangle	\circ	\star	\square
R_3			\square	\star
R_4	\star	\square	\triangle	\circ

Now, in column C_2 we can have to place symbol \star symbol in place of ?, as if can not be use in R_1C_1 , symbol \star is already placed in R_4C_1 .

	C_1	C_2	C_3	C_4
R_1		\star	\circ	\triangle
R_2	\triangle	\circ	\star	\square
R_3			\square	\star
R_4	\star	\square	\triangle	\circ

After placing symbols at R_3C_1, R_3C_2 and R_1C_1 the figure will look alike.

	C_1	C_2	C_3	C_4
R_1	□	*	○	△
R_2	△	○	*	□
R_3	○	△	□	*
R_4	*	□	△	○

Hence, the correct option is (B).

Q.6 to Q.10 Carry Two Marks Each

Question 6

In a recently held parents-teacher meeting, the teachers had very few complaints about Ravi. After all, Ravi was a hardworking and kind student. Incidentally, almost all of Ravi's friends at school were hard working and kind too, but the teachers drew attention to Ravi's complete lack of interest in sports. The teachers believed that along with some of his friends who shows similar disinterest in sports, Ravi needed to engage in some sports for his overall development.

Based only on the information provided above, which one of the following statements can be logically inferred with certainty?

- (A) All of Ravi's friends are hardworking and kind.
- (B) No one who is not a friend of Ravi is hardworking and kind.
- (C) None of Ravi's friends are interested in sports.
- (D) Some of Ravi's friends are hardworking and kind.

Ans. (D)

Sol. Given :

In a recently held parents teacher meeting, the teachers had very few complaints about Ravi. After all, Ravi was a hardworking and kind student. Incidentally, almost all of Ravi's friends at school were hard working and kind too. But the teachers drew attention to Ravi's complete lack of interest in sports. The teachers believed that along with some of his friends who shows similar disinterest in sports, Ravi needed to engage in some sports for his overall development.

Option (A) is not correct, as only some of Ravi's friend are hardworking and kind.

Option (B) is not correct, as almost all Ravi's friend are hardworking and kind.

Option (C) is not correct, as some of the Ravi's friend are interested in sports.

Option (D) is correct, as all of Ravi's friends are hardworking and kind.

Hence, the correct option is (D).

Question 7

There are two inequalities :

$$p^2 - 4q < 4$$

$$3p + 2q < 6$$

Where p and q are positive integers. The value of p + q is _____.

- (A) 2
(C) 3

- (B) 1
(D) 4

Ans. (A)

Sol. $3p + 2q < 6$
 $6p + 4q < 12$
 $4q < 12 - 6p$ (i)
 $p^2 - 4q < 4$
 $p^2 - 4 < 4q$ (ii)
 $p^2 - 4 < 12 - 6p$
 $p^2 + 6p - 16 < 0$
 $p^2 + 8p - 2p - 16 < 0$
 $p(p + 8) - 2(p + 8) < 0$
 $(p + 8)(p - 2) < 0$
 $p = (-8, 2)$

Since p is positive integer

So, $p = 1$

Using this in equation (i)

$$4q < 12 - 6p \quad (p = 1)$$

$$4q < 6$$

$$q < \frac{3}{2}$$

$$q = 1$$

$$\therefore p + q = 2$$

Hence, the correct option is (A).

Question 8

Which one of the sentence sequence in the given option creates a coherent narrative?

- (i) I could not bring myself to knock
(ii) There was a number of unfamiliar voices coming from the big drawing room and the door was firmly shut.
(iii) The passage was dark for a bit, but then it suddenly opened into a bright kitchen.
(iv) I decided I would rather wander down the passage.
- (A) (iv), (i), (iii), (ii) (B) (iii), (i), (ii), (iv)
(C) (ii), (i), (iv), (iii) (D) (i), (iii), (ii), (iv)

Ans. (C)

Sol. Given :

- I could not bring myself to knock
- There was a number of unfamiliar voices coming from the big drawing room and the door was firmly shut.

3. The passage was dark for a bit, but then it suddenly opened into a bright kitchen.
 4. I decided I would rather wander down the passage.
 We will make pair of two sentence for the sequences which creates a coherent narrative.
 The pairs will be 2-1 and 4-3 which gives a meaningful narrative.
 According to the options, sequence in option (C) will give best coherent meaning.
 Hence, the correct option is (C).

Question 9

How many pairs of sets (S, T) are possible among the subsets of {1, 2, 3, 4, 5, 6} that satisfy the condition that S is subset of T?

- (A) 729 (B) 728
 (C) 665 (D) 664

Ans. (A)

Sol. Let two number be (5, 6)

- $T = \phi$ $S = \phi$ - 1
 $T = 5$ $S = \phi, 5$ - 2
 $T = 6$ $S = \phi, 6$ - 2
 $T = 5, 6$ $S = \phi, 5, 6$ - 3

Here, we get 9 possibilities (1+2+2+3) which is 3^2

So, $(5, 6) \Rightarrow 3^2 = 9$

$(4, 5, 6) \Rightarrow 3^3 = 27$

$(3, 4, 5, 6) \Rightarrow 3^4 = 81$

Similarly, $(1, 2, 3, 4, 5, 6) \Rightarrow 3^6 = 729$

Hence, the correct option is (A).

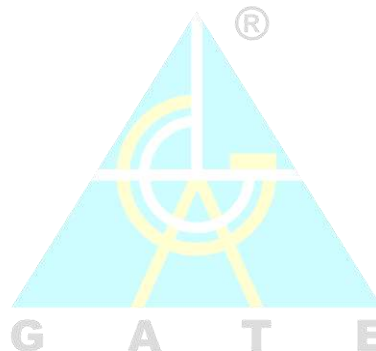

Question 10

An opaque pyramid (shown below), with a square base and isosceles faces, is suspended in the path of a parallel beam of light, such that its shadow is cast on a screen oriented perpendicular to the direction of the light beam. The pyramid can be reoriented in any direction within the light beam. Under these conditions, which one of the shadows P, Q, R, and S is NOT possible?

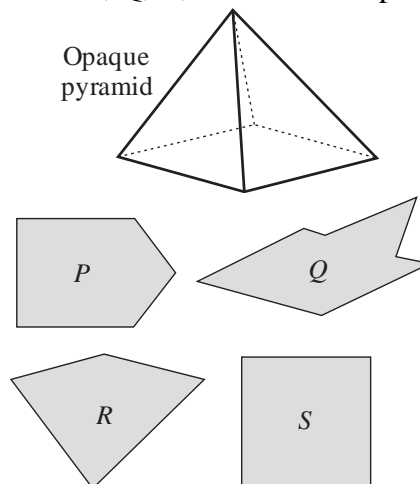

- (A) P (B) Q
(C) R (D) S

Ans. (B)

Sol. Given :

An opaque pyramid with a square base and isosceles faces is suspended in the path of a parallel beam of light such that its shadow is cast on a screen oriented perpendicular to the direction of the light beam.

The pyramid can be reoriented in any direction within the light beam under these conditions the shadow Q, is not possible.

Hence, the correct option is (B).

Technical Part

Q.11 to Q.35 Carry One Mark Each

Question 11

[Engineering Mathematics]

A machine produces a defective component with a probability of 0.015. The number of defective components in a packed box containing 200 components produced by the machine follows a Poisson distribution. The mean and the variance of the distributions are

- (A) 3 and 3 respectively (B) $\sqrt{3}$ and $\sqrt{3}$ respectively
(C) 0.015 and 0.015 respectively (D) 3 and 9 respectively

Ans. (A)

Sol. $p = 0.015$ (very very small)

$n = 200$ (large)

Mean = Variance = $\lambda = np = 200(0.015) = 3$

Mean = Variance = 3

Question 12

[Engineering Mathematics]

The figure shows the plot of a function over the interval $[-4, 4]$ which one of the options given correctly identifies the function?

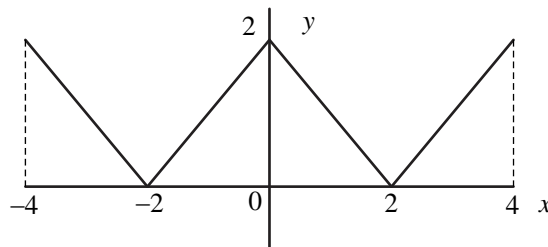

- (A) $|2 - x|$ (B) $|2 - |x||$
(C) $|2 + |x||$ (D) $2 - |x|$

Ans. (B)

Sol. At $x = -4$ $y = |2 - |-4|| = 2$

At $x = -2$ $y = |2 - |-2|| = 0$

At $x=0$ $y=|2-|0||=2$

At $x=2$ $y=|2-|2||=0$

At $x=4$ $y=|2-|4||=2$

Hence, the correct option is (B).

Question 13

[Industrial Engineering]

With reference to the EOQ model, which one of the options given is correct?

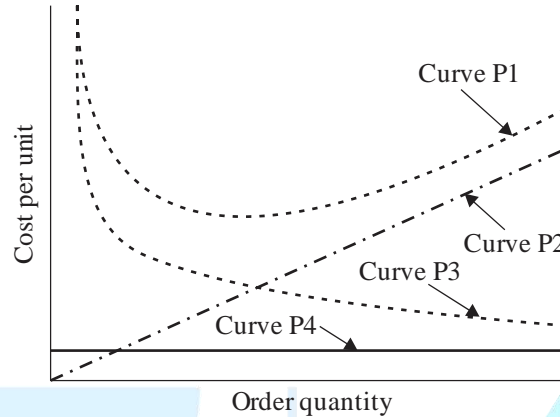

- (A) Curve P1: Total cost, Curve P2: Holding cost, Curve P3: Setup cost, and Curve P4: Production cost
- (B) Curve P1: Holding cost, Curve P2: Setup cost, Curve P3: Production cost, and Curve P4: Total cost.
- (C) Curve P1: Production cost, Curve P2: Holding cost, Curve P3: Total cost, and Curve P4: Setup cost
- (D) Curve P1: Total cost, Curve P2: Production cost, Curve P3: Holding cost, and Curve P4: Setup cost.

Ans. (A)

Sol.

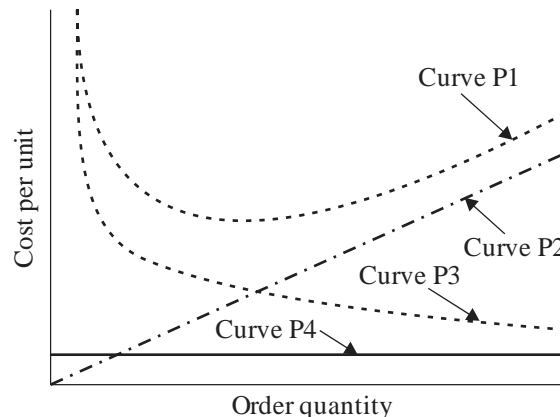

Where, C_1 = Total cost, C_2 = Holding cost, C_3 = Setup cost, C_4 = Production cost

Hence, the correct option is (A).

Question 14

[Industrial Engineering]

Which one of the options given represents the feasible region of the linear programming model:

$$\text{Maximize } z = 45x_1 + 60x_2, \quad x_1 \leq 45, \quad x_2 \leq 50, \quad 10x_1 + 10x_2 \geq 600, \quad 25x_1 + 5x_2 \leq 750$$

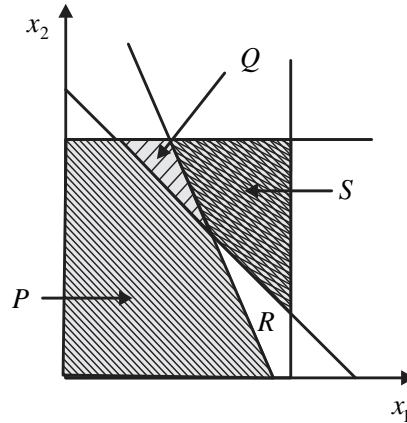

- (A) Region P
- (B) Region Q
- (C) Region R
- (D) Region S

Ans. (B)

Sol. Maximize $z = 45x_1 + 60x_2$

$$x_1 \leq 45$$

$$x_2 \leq 50$$

$$10x_1 + 10x_2 \geq 600$$

$$25x_1 + 5x_2 \leq 750$$

Since, there is only Q region is enclosed by all the equation.

Hence, the correct option is (B).

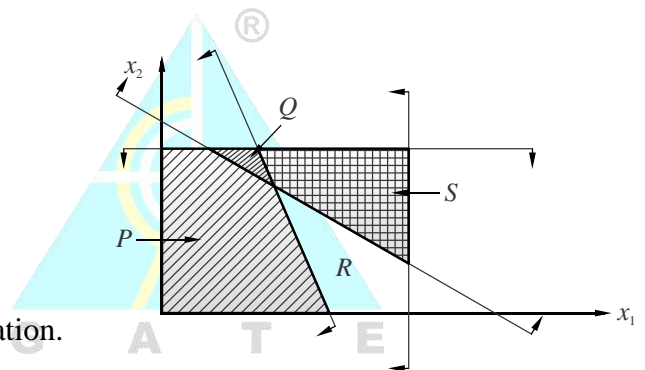

Question 15

[Theory of Machine]

A cuboidal part has to be accurately positioned first, arresting six degrees of freedom and then clamped in a fixture, to be used for machining. Locating pins in the form of cylinders with hemi-spherical tips are to be placed on the fixture for positioning. Four different configurations of locating pins are proposed as shown. Which one of the options given is correct?

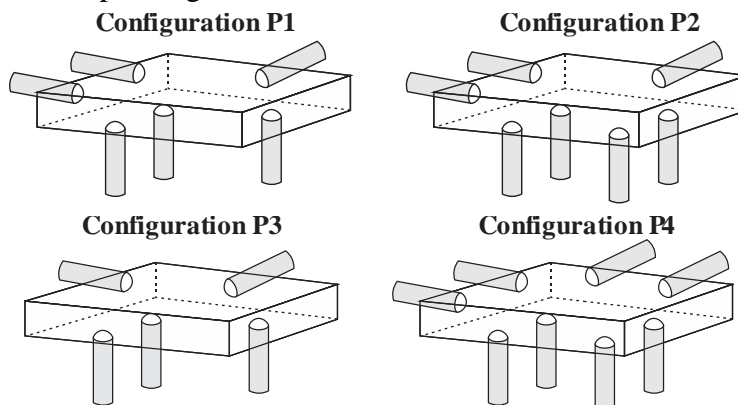

- (A) Configuration P1 arrests 6 degrees of freedom, while Configurations P2 and P4 are over-constrained and Configuration P3 is under-constrained.
- (B) Configuration P2 arrests 6 degrees of freedom, while Configurations P1 and P3 are over-constrained and Configuration P4 is under-constrained.
- (C) Configuration P3 arrests 6 degrees of freedom, while Configurations P2 and P4 are over-constrained and Configuration P1 is under-constrained.
- (D) Configuration P4 arrests 6 degrees of freedom, while Configurations P1 and P3 are over-constrained and Configuration P2 is under-constrained.

Ans. (A)

Sol. By providing 6 pin 6 degrees of freedom are arrested. But in Configurations P2 and P4 number of pins are more than six so they are over constrained and Configuration P3 numbers of pins are less than six so it is under constrained.

Hence, the correct option is (A).

Question 16

[Mechanics of Solid]

The effective stiffness of a cantilever beam of length L and flexural rigidity EI subjected to transverse tip load W is

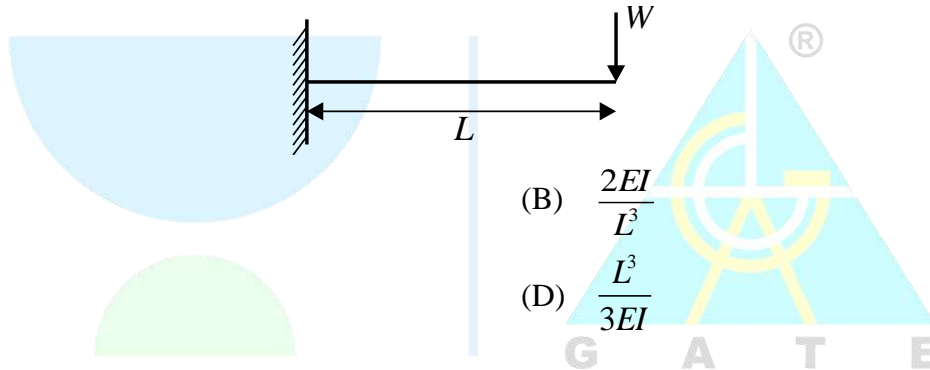

- (A) $\frac{3EI}{L^3}$
- (B) $\frac{2EI}{L^3}$
- (C) $\frac{L^3}{2EI}$
- (D) $\frac{L^3}{3EI}$

Ans. (A)

Sol. As we know, $\text{stiffness} = \frac{\text{Load}}{\text{Deflection}}$

$$k = \frac{W}{\frac{WL^3}{3EI}} = \frac{3EI}{L^3}$$

Hence, the correct option is (A).

Question 17

[Engineering Mechanics]

The options show frames consisting of rigid bars connected by pin joints. Which one of the frames is non-rigid?

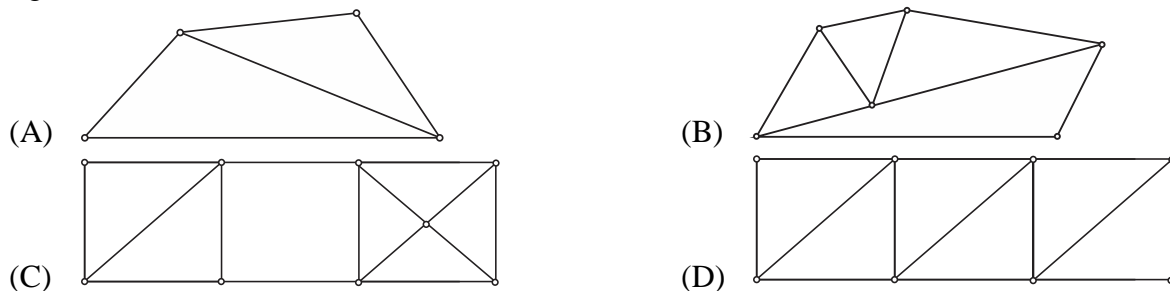

Ans. (C)

Sol. Option (A) : $m=9, j=6$

$$m+3=12$$

$$2j=12$$

$$m+3=2j \rightarrow \text{Rigid}$$

Option (B) : $m=5, j=4$

$$m+3=8$$

$$2j=8$$

$$m+3=2j \rightarrow \text{Rigid}$$

Option (C) : $m=13, j=8$

$$m+3=16$$

$$2j=16$$

$$m+3=2j \rightarrow \text{Rigid}$$

Option (D) : $m=13, j=9$

$$m+3=16$$

$$2j=18$$

$$m+3 < 2j \rightarrow \text{Non - rigid}$$

Hence, the correct option is (C).

Question 18

The S-N curve from a fatigue test for steel is shown. Which of the following options gives endurance limit?

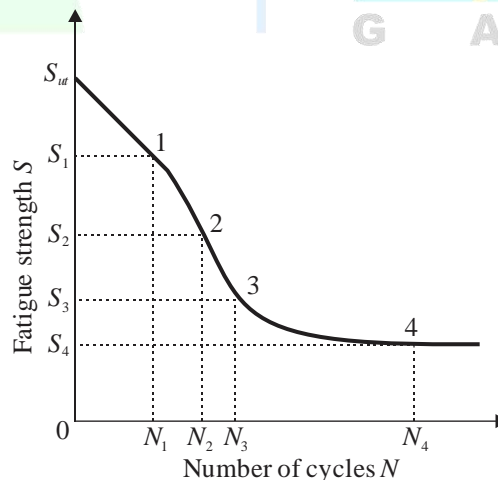

(A) S_u

(B) S_2

(C) S_3

(D) S_4

Ans. (D)

Sol. As we know in SN diagram, SN curve become asymptotic for infinite life, which is called endurance limit. Hence, the correct option is (D).

Question 19

[Fluid Mechanics]

Air (density 1.2 Kg/m^3 , $\nu = 1.5 \times 10^{-5} \text{ m}^2/\text{s}$) flow over a flat plate with a free stream velocity of 2 m/s . the wall shear stress of a Location 15 mm from the leading, edge is τ_w . What is the wall shear stress of a location 30 mm from the leading edge?

- (A) $\tau_w / 2$ (B) $\sqrt{2}\tau_w$
(C) $2\tau_w$ (D) $\frac{\tau_w}{\sqrt{2}}$

Ans. (D)

Sol. $Re = \frac{u_\infty L}{\nu} = \frac{2 \times 0.03}{1.5 \times 10^{-5}}$

$Re = 4000 < 5 \times 10^5$

$\frac{\tau_{w_2}}{\tau_{w_1}} = \left(\frac{x_1}{x_2}\right)^{\frac{1}{2}} = \left(\frac{15}{30}\right)^{\frac{1}{2}}$

$\tau_{w_2} = \frac{\tau_{w_1}}{\sqrt{2}}$

Hence, the correct option is (D).

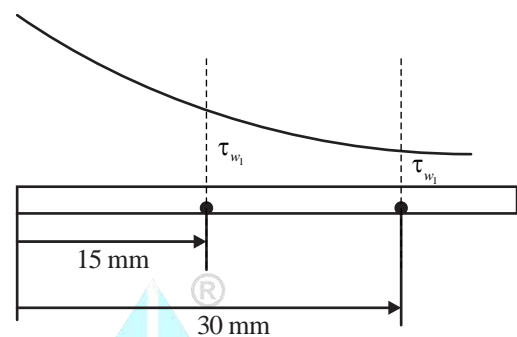

Question 20

[Fluid Mechanics]

Consider an isentropic flow of air ($\gamma = 1.4$) through a duct as shown in figure. The variation in the flow across the cross sectional are negligible. The flow condition at Location-1 are given as follows.

$P_1 = 100 \text{ kPa}$, $\rho_1 = 1.2 \text{ Kg/m}^3$, $u_1 = 400 \text{ m/s}$

The duct cross section area at Location-2 is given by $A_2 = 2A_1$, where A_1 denotes the duct cross sectional area at Location 1. Which one of the given statement about the velocity u_2 and pressure P_2 at Location 2 is True?

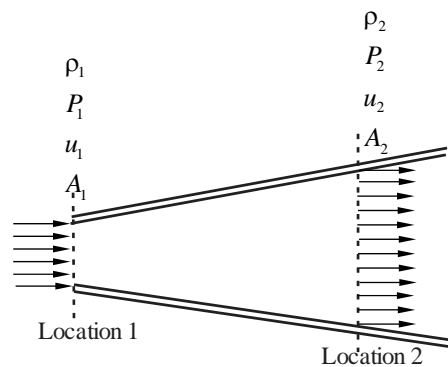

- (A) $u_2 < u_1, P_2 < P_1$ (B) $u_2 < u_1, P_2 > P_1$
(C) $u_2 > u_1, P_2 < P_1$ (D) $u_2 > u_1, P_2 > P_1$

Ans. (C)

Sol. $T_1 = \frac{P_1}{\rho_1 R} = \frac{100}{1.2 \times 0.287}$

$$T_1 = 290.36 \text{ K}$$

$$Ma_1 = \frac{u_1}{c_1} = \frac{400}{\sqrt{1.4 \times 287 \times 290.36}}$$

$Ma_1 = 1.017 \rightarrow$ flow is supersonic \rightarrow If supersonic Nozzle.

So, $u_2 > u_1$ $P_1 > P_2$

Hence, the correct option is (C).

Question 21**[Heat Transfer]**

Consider incompressible laminar fluid flow of constant property Newtonian fluid in an isothermal circular tube. Flow is steady with fully developed temperature and velocity profiles. The Nusselt number for this flow depends on.

- (A) Neither the Reynold number nor the Prandtl number
- (B) Both the Reynold number and Prandtl number
- (C) The Reynold number but not the Prandtl number
- (D) The Prandtl number but not the Reynold number

Ans. (A)

Sol. In incompressible laminar fluid flow for isothermal circular tube the value of Nusselt number is constant.

For constant heat flux = 4.36

For constant wall temperature = 3.66

Hence, the correct option is (A).

Question 22**[Thermodynamics]**

A heat engine external heat (Q_H) from a thermal reservoir at a temperature of 1000 K and reject heat (Q_L) to a thermal reservoir at a temperature of 100 K while producing work (W). Which one of the combination of [Q_H , Q_L & W] given is allowed.

- (A) $Q_H = 2000 \text{ J}$, $Q_L = 500 \text{ J}$, $W = 1000 \text{ J}$
- (B) $Q_H = 2000 \text{ J}$, $Q_L = 750 \text{ J}$, $W = 1250 \text{ J}$
- (C) $Q_H = 6000 \text{ J}$, $Q_L = 500 \text{ J}$, $W = 5500 \text{ J}$
- (D) $Q_H = 6000 \text{ J}$, $Q_L = 600 \text{ J}$, $W = 5500 \text{ J}$

Ans. (B)

Sol. Given : According to 1st law of thermodynamics,

$$Q_H = Q_L + H$$

- (A) $2000 \neq 500 + 1000$
- (B) $2000 = 750 + 1250$
- (C) $6000 \neq 600 + 5500$
- (D) $6000 = 500 + 5500$

According to 2nd law of Thermodynamics

Clausius Inequality, $\oint \frac{dQ}{T} \leq 0$

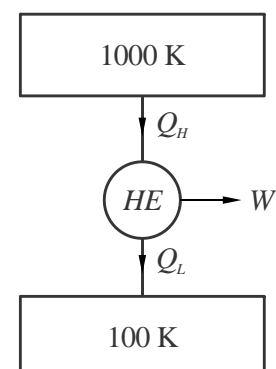

$$\frac{Q_H}{1000} - \frac{Q_L}{100} \leq 0$$

Option (D) :

$$\frac{6000}{1000} - \frac{500}{100} \leq 0$$

$$(6 - 5) \leq 0$$

$$+1 > 0$$

$$+1 \not\leq 0$$

Option (B) :

$$\frac{2000}{1000} - \frac{750}{100} \leq 0$$

$$(2 - 7.5) \leq 0$$

$$-5.5 < 0$$

Option (B) is satisfy 1st law and 2nd law of Thermodynamics so option (B) is correct.

Hence, the correct option is (B).

Question 23

[Manufacturing Engg.]

Two surfaces P and Q are to be joined together. In which of the given joining operations (s), there is no melting of the two surfaces P and Q for creating the joint?

- (A) Arc welding
- (B) Brazing
- (C) Adhesive bonding
- (D) Spot welding

Ans. (B) & (C)

Sol. In brazing and adhesive bonding, there is no melting of the two surfaces P and Q for creating the joint. Hence, the correct options are (B) & (C).

Question 24

[Strength of Material]

A beam is undergoing pure bending as shown in figure. The stress (σ) strain (ϵ) curve for the material also given .The yield strength of the material is σ_y Which of the options given represent(s) the bending stress distribution at cross section A-A after plastic yielding

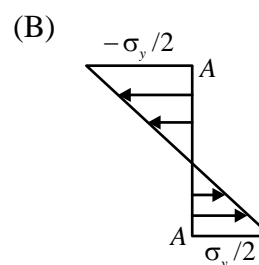
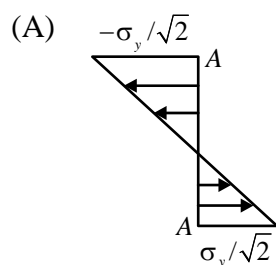
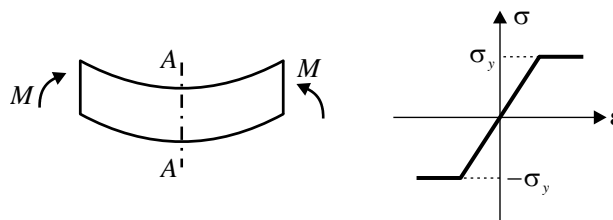

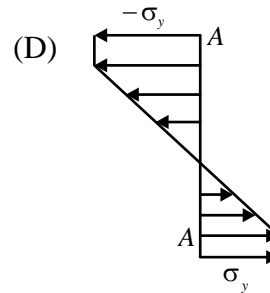
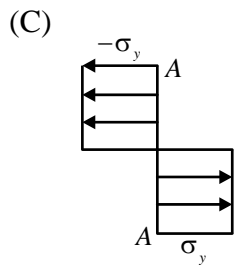

Ans. (C) & (D)

Sol. After Plastic Yielding, bending stress will remain constant.

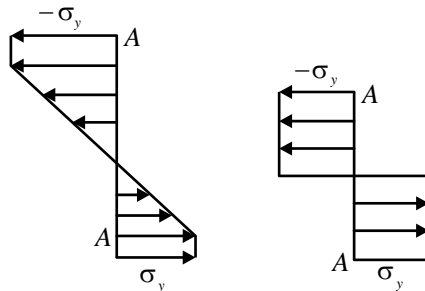

Hence, the correct options are (C) & (D).

Question 25

[Manufacturing Engg.]

In a metal casting process to manufacture parts, both pattern and moulds provide shape by dictating where the material are should and should not go. Which of the option(s) given correctly describe(s) the mould and the pattern?

- (A) Mould walls indicates boundaries within which the molten part material is allowed while pattern walls indicates boundaries of regions where mould material is not allowed.
- (B) Moulds can be used to make patterns
- (C) Pattern walls indicates boundaries within which the molten part material is allowed while mould walls indicates boundaries of regions where mould material is not allowed.
- (D) Patterns can be used to make moulds

Ans. (A), (B) & (D)

Sol. Mould walls indicates boundaries within which the molten part material is allowed while pattern walls indicates boundaries of regions where mould material is not allowed.

Moulds can be used to make patterns.

Patterns can be used to make moulds.

Hence, the correct options are (A), (B) & (D).

Question 26

[Machine Design]

The principal stresses at a point P in a solid are 70 MPa, -70 MPa and 0, the yield stress of the material is 100 MPa, which predictions about material failure at P is/are correct

- (A) Maximum normal stress theory predicts that the material fails.
- (B) Maximum shear stress theory predicts that material fails.
- (C) Maximum normal stress theory predicts that material does not fail.
- (D) Maximum shear stresses theory predicts that material does not fail.

Ans. (B) & (C)

Sol. Given : $\sigma_1 = 70$ MPa

$$\sigma_2 = -70 \text{ MPa}$$

$$\sigma_3 = 0$$

$$\sigma_y = 100 \text{ MPa}$$

According to maximum normal stress theory to avoid failure

$$\sigma_{\max} < S_{yt}$$

$$70 < 100$$

So, it will be safe according to maximum normal stress theory.

According to maximum shear stress theory to avoid failure.

$$\tau_{\max} < 0.5S_{yt}$$

$$\frac{\sigma_1 - \sigma_2}{2} < 0.5 \times 100$$

$$\frac{70 + 70}{2} < 50$$

$$70 < 50$$

$$70 > 50$$

So, it will fail according to shear stress theory.

Hence, the correct options are (B) and (C).

Question 27

Which of the plot(s) shown is/are valid Mohr's circle representation of a plane stress state in a material? (The center of each circle is represented by O .)

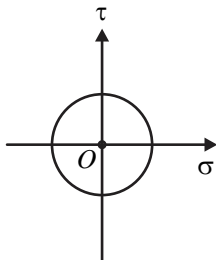

Fig.: M_1

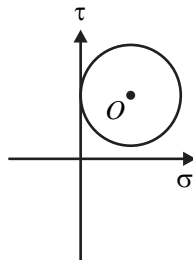

Fig.: M_2

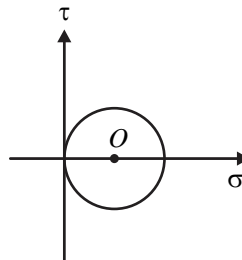

Fig.: M_3

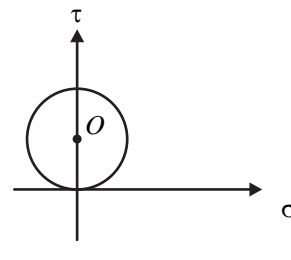

Fig.: M_4

(A) M_1

(B) M_2

(C) M_3

(D) M_4

Ans. (A) & (C)

Sol. As we know,

The radius of Mohr's circle always lies in (σ) axis.

Hence, the correct options are (A) and (C).

Question 28

[Heat Transfer]

Consider a laterally insulated rod of length L and constant thermal conductivity K . Assuming one dimension heat conduction in the rod, which of the following steady state temperature profile(s) can occur without heat generation.

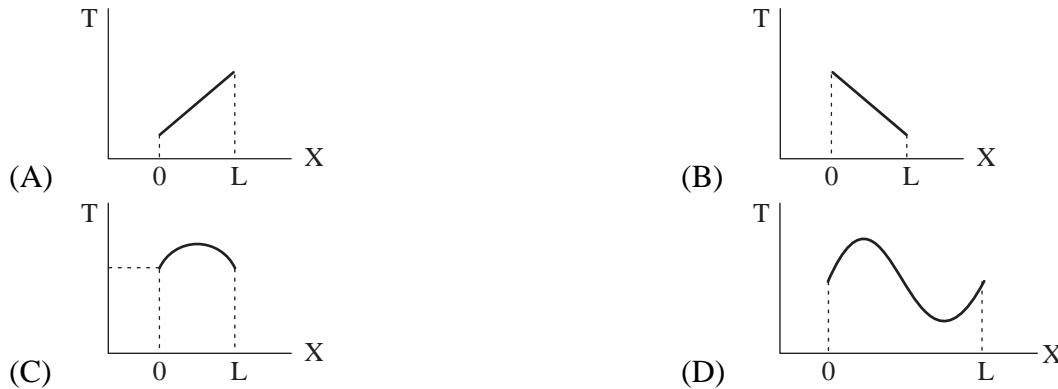

Ans. (A) & (B)
Sol.

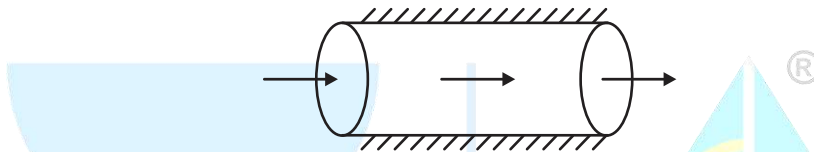

This is heat flow through constant cross – sectional area. Without volumetric heat Generation. So only linear temperature profile is possible. Hence, the correct options are (A) & (B).

Question 29

[Theory of Machines]

Two meshing spur gears 1 and 2 with diametral pitch of 8 teeth per mm and an angular velocity ratio $\frac{|\omega_2|}{|\omega_1|} = \frac{1}{4}$, have their centres 30 mm apart. The number of teeth on driver (gear 1) is _____.

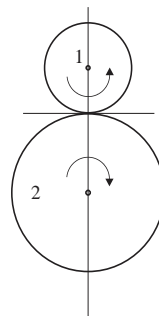

Ans. 95.999 to 96.001

Sol. Given : $r_1 + r_2 = 30$ mm

$$\frac{\omega_2}{\omega_1} = \frac{1}{4}$$

$$\frac{m}{2}(T_1 + T_2) = 30$$

$$m(T_1 + T_2) = 60$$

$$\therefore P_d = \frac{1}{3}$$

$$m = \frac{1}{P_d} = \frac{1}{\frac{1}{3}} = 3$$

$$\therefore \frac{1}{8}(T_1 + T_2) = 60$$

$$T_1 + T_2 = 480$$

$$\frac{\omega_2}{\omega_1} = \frac{T_1}{T_2} = \frac{1}{4} \Rightarrow 4T_1 = T_2$$

$$4T_1 + T_1 = 480$$

$$5T_1 = 480$$

$$T_1 = 96$$

Hence, the correct answer is 95.

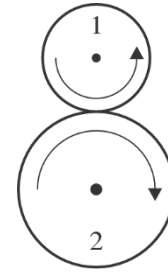

Question 30

[Theory of Machines]

The figure shows a block of mass $m = 20$ kg attached to a pair of identical linear springs each having a spring constant $k = 1000$ N/m. The block oscillates on a frictionless horizontal surface. Assuming free vibrations, the time taken by the block to complete ten oscillations is _____ seconds. Take $\pi = 3.14$

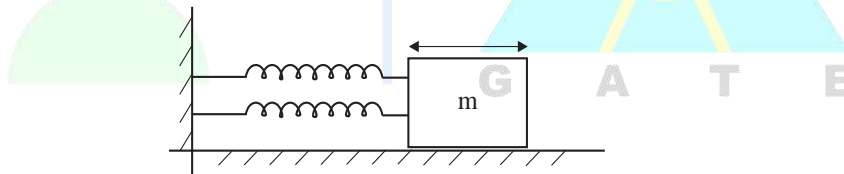

Ans. 6.27 to 6.29

Sol. $k_{eq} = k_1 + k_2 = 2000$ N/m

$$\omega_n = \sqrt{\frac{k_{eq}}{m}} = \sqrt{\frac{2000}{20}} \text{ rad/s}$$

$$f_n = \frac{\omega_n}{2\pi} \text{ Hz}$$

$$T = \frac{1}{f_n} \text{ sec.}$$

$$\text{Total time} = 10 \times \frac{1}{f_n} \text{ sec} = 10 \times \frac{2\pi}{\sqrt{\frac{2000}{20}}} \text{ sec} = 6.283 \text{ sec.}$$

Hence, the correct answer is 6.283.

Question 31

[Engineering Mathematics]

A vector field $B(x, y, z) = x\hat{i} + y\hat{j} - 2z\hat{k}$ is defined over a conical region having height $h = 2$, base radius $r = 3$ and axis along z , as shown in the figure. The base of the cone lies in the $x-y$ plane and is centered at the origin.

If \mathbf{n} denotes the unit outward normal to the curved surface S of the cone, the value of the integral $\int_S B \cdot \mathbf{n} dS$ equals _____. (Answer in integer)

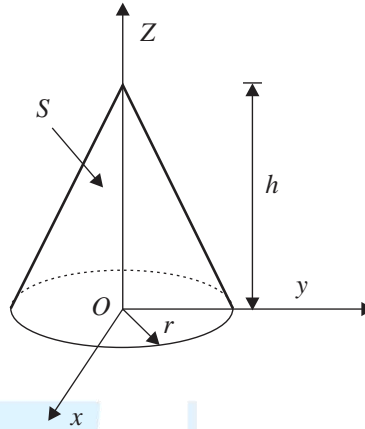

Ans. 0.001 to 0.001

Sol. $\vec{F} = x\vec{i} + y\vec{j} - 2z\vec{k}$

$$\nabla \cdot \vec{F} = \frac{\partial}{\partial x}(x) + \frac{\partial}{\partial y}(y) + \frac{\partial}{\partial z}(-2z) = 1 + 1 - 2 = 0$$

By Gauss divergence theorems,

$$\iint_S \vec{F} \cdot \hat{n} ds = \iiint_V \nabla \cdot \vec{F} du = 0$$

Hence, the correct answer is 0.



Question 32

[Engineering Mathematics]

A linear transformation maps a point (x, y) in the plane to the point (\hat{x}, \hat{y}) according to the rule

$$\hat{x} = 3y, \hat{y} = 2x,$$

Then, the disc $x^2 + y^2 \leq 1$ gets transformed to a region with an area of equal to _____. (Rounded off to two decimals) [Use $\pi = 3.14$]

Ans. 18.80 to 18.90

Sol. Given :

$$\hat{x} = 3y \text{ and } \hat{y} = 2x$$

$$\therefore y = \frac{\hat{x}}{3} \text{ and } x = \frac{\hat{y}}{2}$$

The given region,

$$x^2 + y^2 \leq 1$$

$$\text{Or } \left(\frac{\hat{y}}{2}\right)^2 + \left(\frac{\hat{x}}{3}\right)^2 \leq 1$$

$$\frac{(\hat{y})^2}{4} + \frac{(\hat{x})^2}{9} \leq 1$$

This is equation of an ellipse with semi major axis, $a = 3$ and semi-minor axis, $b = 2$, thus area of transformed region is

$$A = \pi ab = 6\pi \approx 18.84 \text{ units.}$$

Hence, the correct answer is 18.84.

Question 33

[Engineering Mathematics]

The value of k that makes the complex-valued function $f(z) = e^{-kx}(\cos 2y - i \sin 2y)$ analytic, where $z = x + iy$, is _____.

Ans. 1.999 to 2.001

Sol. $f(z) = u + iv$

$$f(z) = e^{-kx} \cos 2y - i e^{-kx} \sin 2y$$

$$u = e^{-kx} \cos 2y, v = -e^{-kx} \sin 2y$$

Cauchy Riemann equation, $\frac{\partial u}{\partial x} = \frac{\partial v}{\partial y}$

$$\frac{\partial}{\partial x}(e^{-kx} \cos 2y) = \frac{\partial}{\partial y}(-e^{-kx} \sin 2y)$$

$$e^{-kx}(-k) \cos 2y = -e^{-kx} \cos 2y \times 2$$

$$k = 2$$

Hence, the correct answer is 2.

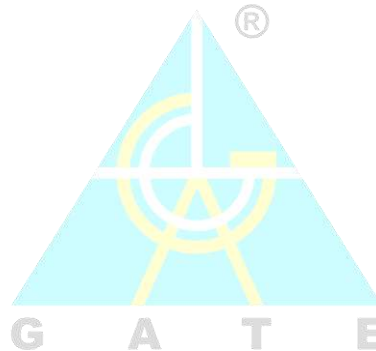

Question 34

[Machine Design]

The braking system shown in the figure uses a belt to slow down a pulley rotating in the clockwise direction by the application of a force P . The belt wraps around the pulley over an angle $\alpha = 270$ degrees. The coefficient of friction between the belt and the pulley is 0.3. The influence of centrifugal forces on the belt is negligible. During braking, the ratio of the tensions T_1 to T_2 in the belt is equal to _____. (Rounded off to two decimal places)

Take $\pi = 3.14$.

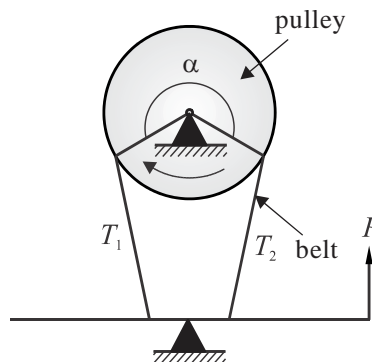

Ans. 4.05 to 4.15**Sol.** Using the equation

$$\frac{T_1}{T_2} = e^{\mu\theta} = e^{0.3 \times \frac{3}{2}\pi}$$

$$\Rightarrow \frac{T_1}{T_2} = 4.11$$

Hence, the correct answer is 4.11.

Question 35**[Heat Transfer]**

Consider a counter-flow heat exchanger with the inlet temperature of two fluids (1 and 2) being $T_{1,in} = 300$ K and $T_{2,in} = 350$ K. The heat capacity rates of the two fluids are $C_1 = 1000$ W/K and $C_2 = 400$ W/K and the effectiveness of the heat exchanger is 0.5. The actual heat transfer rate is _____ kW. [NAT]

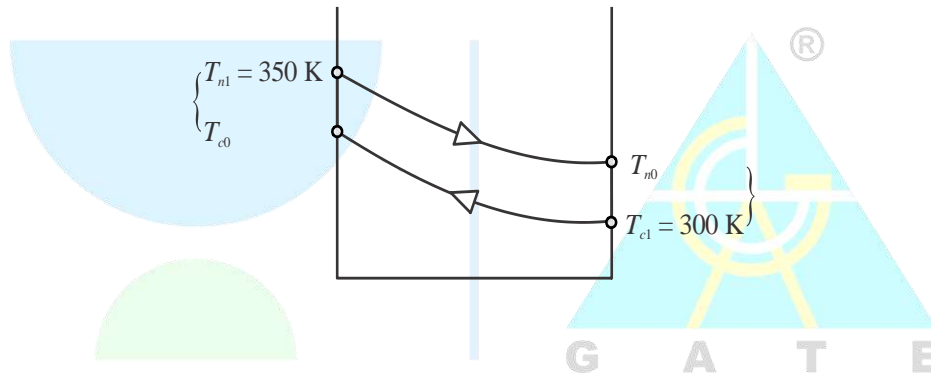
Ans. 9.999 to 10.001**Sol.**Inlet temperature of first fluid $T_{1(in)} = 300$ KInlet temperature of second fluid $T_{2(in)} = 350$ KHeat capacity of first fluid $C_1 = 1000$ W/kHeat capacity of second fluid $C_2 = 400$ W/kEffectiveness of heat exchanger (counter flow) $\varepsilon = 0.5$

As we know,

$$\text{Effectiveness } \varepsilon = \frac{\text{Actual heat transfer}}{\text{maximum possible heat transfer}}$$

$$0.5 = \frac{\text{Actual heat transfer}}{C_{\min} (T_{2(in)} - T_{1(in)})}$$

$$\text{Actual heat transfer} = 0.5 \times 400 \times (350 - 300) = 10 \text{ kW}$$

Hence, the correct answer is 10 kW.

Q.36 to Q.65 Carry Two Marks Each

Question 36

[Engineering Mathematics]

Which one of the options given is the inverse Laplace transform of $\frac{1}{s^3 - s}$? $u(t)$ denotes the unit-step function.

- (A) $\left(-1 + \frac{1}{2}e^{-t} + \frac{1}{2}e^t\right)u(t)$ (B) $\left(\frac{1}{3}e^{-t} - e^t\right)u(t)$
 (C) $\left(-1 + \frac{1}{2}e^{-(t-1)} + \frac{1}{2}e^{(t-1)}\right)u(t-1)$ (D) $\left(-1 - \frac{1}{2}e^{-(t-1)} - \frac{1}{2}e^{(t-1)}\right)u(t-1)$

Ans. (A)

Sol. Given :

$$F(s) = \frac{1}{s^3 - s} = \frac{1}{s(s^2 - 1)} = \frac{1}{s(s-1)(s+1)}$$

On partial fraction decomposition,

$$F(s) = -\frac{1}{s} + \frac{\frac{1}{2}}{s-1} + \frac{\frac{1}{2}}{s+1}$$

$$\begin{aligned} \text{Thus, } L^{-1}(F(s)) &= L^{-1}\left(-\frac{1}{s}\right) + L^{-1}\left(\frac{\frac{1}{2}}{s-1}\right) + L^{-1}\left(\frac{\frac{1}{2}}{s+1}\right) \\ &= -L^{-1}\left(\frac{1}{s}\right) + \frac{1}{2}L^{-1}\left(\frac{1}{s-1}\right) + \frac{1}{2}L^{-1}\left(\frac{1}{s+1}\right) \\ &= -1 + \frac{1}{2}e^t + \frac{1}{2}e^{-t} \end{aligned}$$

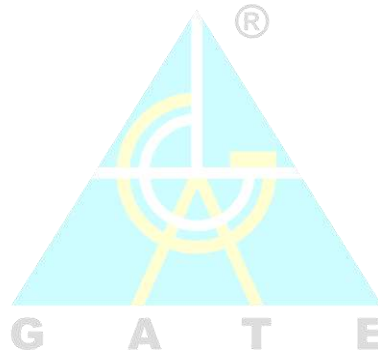

Hence, the correct option is (A).

Question 37

[Engineering Mechanics]

A spherical ball weighing 2 kg is dropped from a height of 4.9 m onto an immovable rigid block as shown in the figure. If the collision is perfectly elastic. What is the momentum vector of the ball (in kg m/s) just after impact?

Take the acceleration due to gravity to be $g = 9.8 \text{ m/s}^2$. Options have been rounded off to one decimal place.

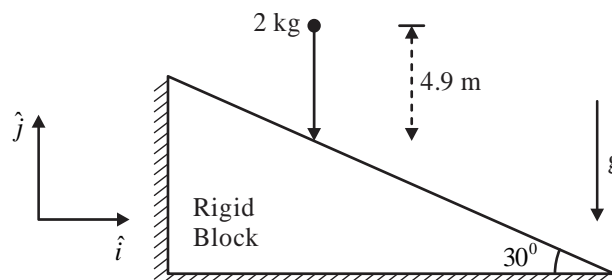

- (A) $19.6\hat{i}$ (B) $19.6\hat{j}$
(C) $17.0\hat{i} + 9.8\hat{j}$ (D) $9.8\hat{i} + 17.0\hat{j}$

Ans. (C)

Sol. $e = 1 = (-) \frac{V'_A - V'_B}{V_A - V_B}$

$V_B = V'_B = 0$

$V_A = -V'_A$

$V_A = \sqrt{2 \times 9.81 \times 4.9}$

$V_A = 9.8 \text{ m/s}$

$V_A = -V'_A = 9.8 \text{ m/s}$

$V_A = 9.8 \cos(30)\hat{i} + 9.8 \sin(30)\hat{j}$

Momentum = $mV_A = 2(9.8 \cos(30)\hat{i} + 9.8 \sin(30)\hat{j})$

Hence, the correct option is (C).

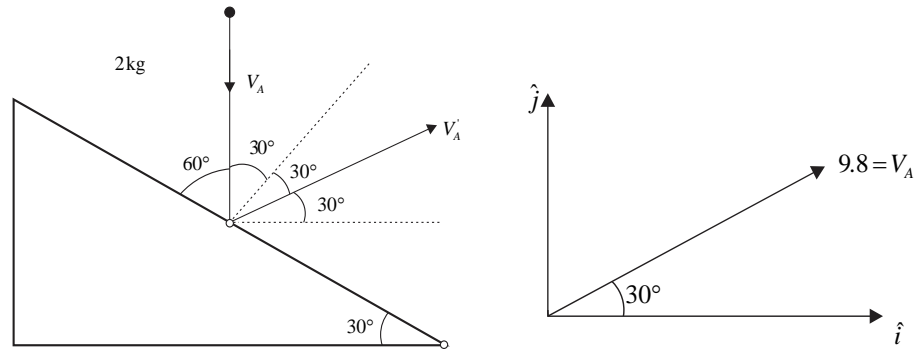

Question 38

[Theory of Machine]

The figure shows a wheel rolling without slipping on a horizontal plane with angular velocity ω_1 . A rigid bar PQ is pinned to the wheel at P while the end Q slides on the floor. What is the angular velocity ω_2 of the bar PQ?

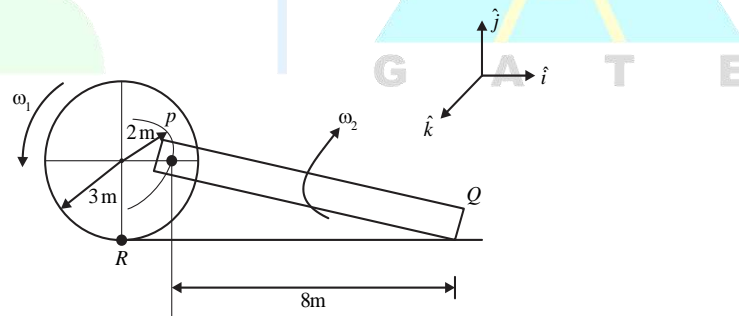

- (A) $\omega_2 = 2\omega_1$ (B) $\omega_2 = \omega_1$
(C) $\omega_2 = 0.5\omega_1$ (D) $\omega_2 = 0.25\omega_1$

Ans. (D)

Sol.

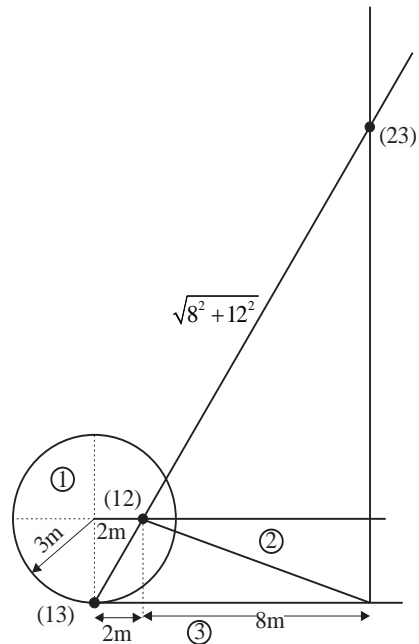

$$\omega_1 (I_{13} I_{12}) = \omega_2 (I_{12} I_{23})$$

$$\omega_1 \times \frac{\sqrt{2^2 + 3^2}}{\sqrt{8^2 + 12^2}} = \omega_2$$

$$0.25\omega_1 = \omega_2$$

Hence, the correct option is (D).

Question 39

[Strength of Materials]

A beam of length L is loaded in the xy -plane by a uniformly distributed load, and by a concentrated tip load parallel to the z -axis, as shown in the figure. The resulting bending moment distribution about the y and the z axes are denoted by M_y and M_z , respectively.

Which one of the options given depict qualitatively CORRECT variation of M_y and M_z along the length of the beam?

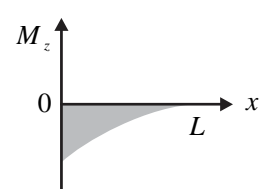
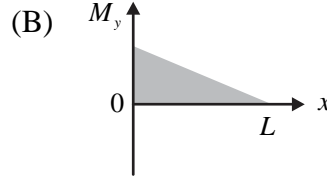
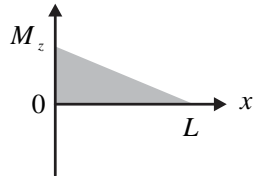
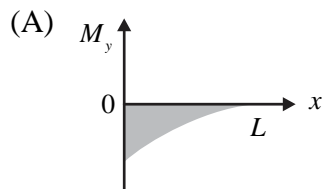
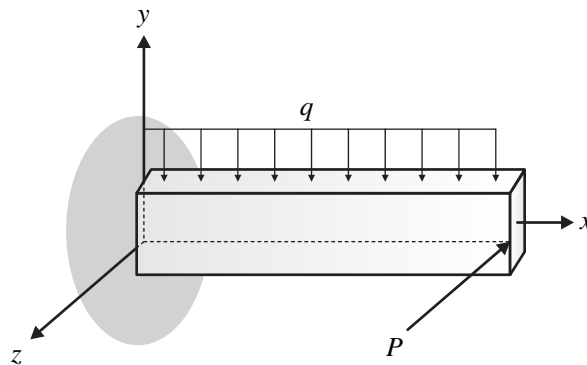

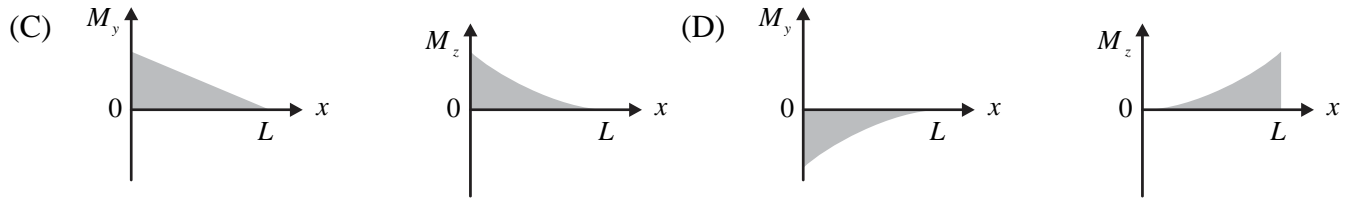

Ans. (B)

Sol. The vertical bending moment diagram in x - y plane due to uniformly distributed load is given as :

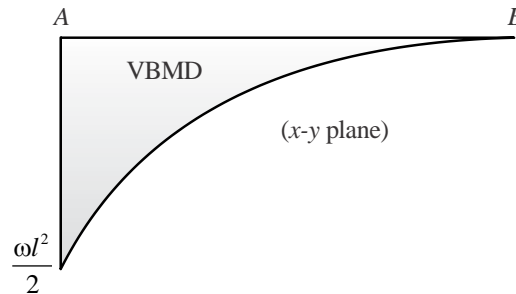

The horizontal bending moment diagram due to horizontal point load is given as :

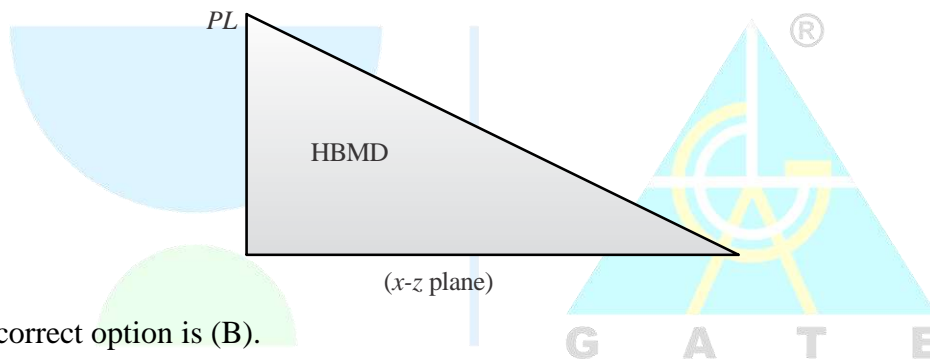

Hence, the correct option is (B).

Question 40

[Strength of Materials]

The figure shows a thin-walled open-top cylindrical vessel of radius r and wall thickness t . The vessel is held along the brim and contains a constant-density liquid to height h from the base. Neglect atmospheric pressure, the weight of the vessel and bending stresses in the vessel walls.

Which one of the plots depicts qualitatively CORRECT dependence of the magnitudes of axial wall stress (σ_1) and circumferential wall stress (σ_2) on y ?

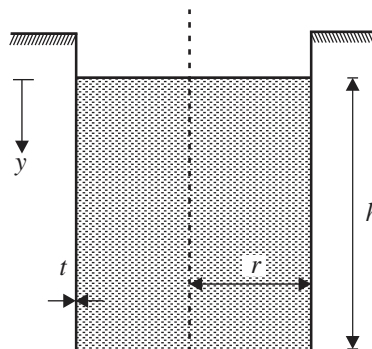

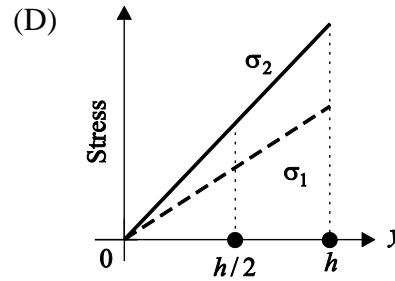
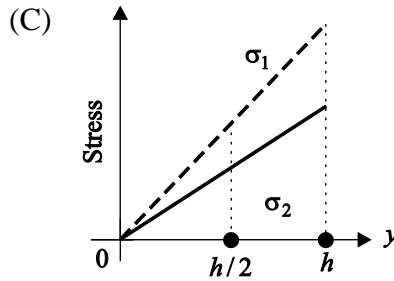
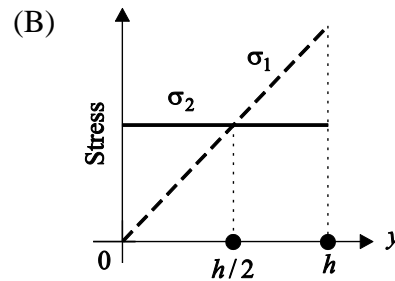
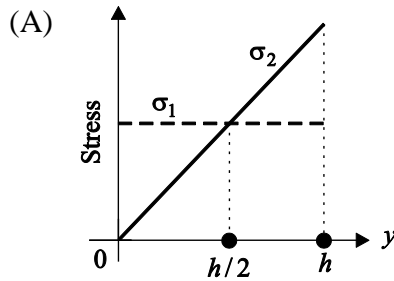

Ans. (A)

Sol. As we move from the free surface towards bottom, the pressure variation can be written as:

$$P = \rho gh$$

$$\text{Now, } \sigma_h = \frac{PD}{2t} = \rho gh \left(\frac{D}{2t} \right)$$

$$\therefore \sigma_h \propto h$$

Longitudinal stress will be developed because of the total amount of fluid and since this amount is constant, the longitudinal stress will be constant.

Hence, the correct option is (A).

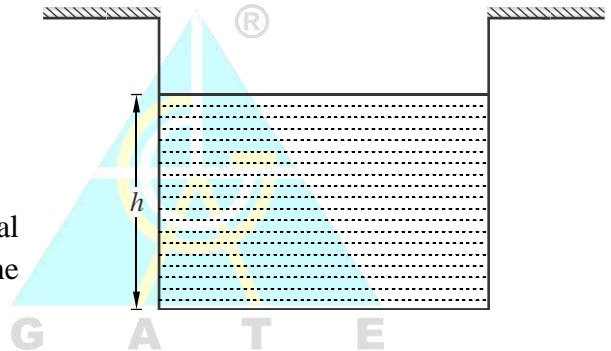

Question 41

[Thermodynamics]

Which of the following statement is FALSE?

- (A) For an ideal gas, the enthalpy is independent of pressure.
- (B) For a real gas going through an adiabatic reversible process, the process equation is given by $PV^\gamma = \text{constant}$, where P is the pressure, V is the volume and γ is the ratio of the specific heats of the gas at constant pressure and constant volume.
- (C) For an ideal gas undergoing a reversible polytropic process $PV^{1.5} = \text{constant}$, the equation connecting the pressure, volume and temperature of the gas at any point along the process is $\frac{P}{R} = \frac{mT}{V}$, where R is the gas constant and m is the mass of the gas.
- (D) Any real gas behaves as an ideal gas at sufficiently low pressure and high temperature.

Ans. (B)

Sol. Explanation: $Pv^\gamma = C$ is applicable for only ideal gas.

Hence, the correct option is (B).

Question 42

[Thermodynamics]

Consider a fully adiabatic piston-cylinder arrangement as shown in figure. The piston is mass less and cross-sectional area of the cylinder is A . The fluid inside the cylinder is Air (perfect gas) with $\gamma = C_p / C_v$ for air. The piston is initially located at a position L_1 . The initial pressure of the air inside the cylinder is $P_1 \gg P_0$, where P_0 is the atm. The stop S_1 is instantaneously removed and the piston moves to the position L_2 , where the equilibrium pressure of air inside the cylinder is $P_2 \gg P_0$. What is the work done by piston on the atmosphere during this process?

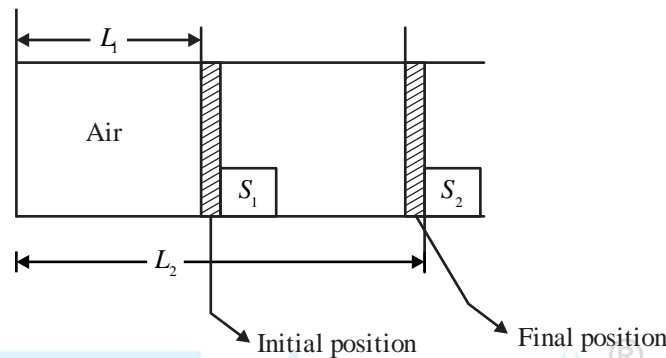

(A) 0

(C) $P_1 A L_1 \ln \frac{L_1}{L_2}$

(B) $P_0 A (L_2 - L_1)$

(D) $\frac{(P_2 L_2 - P_1 L_1) A}{1 - \gamma}$

Ans. (B)
Sol.

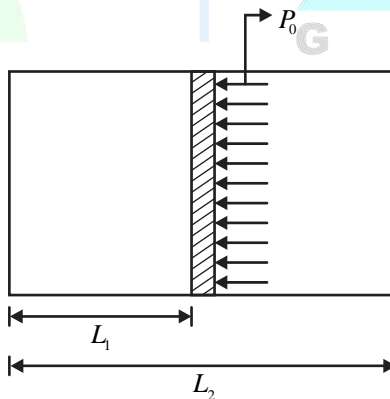

Work done by piston on
Atmosphere air = $P_0 (\Delta V) = P_0 A (L_2 - L_1)$
Hence, the correct option is (B).

Question 43

[Heat Transfer]

A cylindrical rod of length h and diameter d is placed inside a cube enclosure of side length L . S denote the inner surface of the cube, the view factor F_{S-S} is

(A) 0

(B) 1

(C) $\frac{\pi dh + \frac{\pi}{2} d^2}{6L^2}$

(D) $1 - \left(\frac{\pi dh + \frac{\pi}{2} d^2}{6L^2} \right)$

Ans. (D)

Sol. Given : Inner surface of cube = S

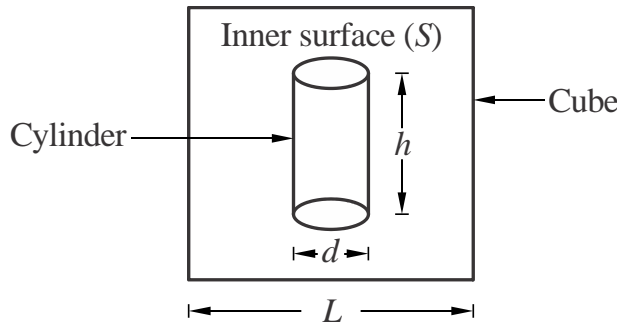

Let, surface of cylinder is 1 and surface of cube is 2.

As we know,

$$F_{21} + F_{22} = 1$$

$$F_{22} = F_{ss} = 1 - F_{21}$$

$$F_{11} + F_{12} = 1$$

From diagram : $F_{11} = 0$ and $F_{12} = 1$

By Reciprocity theorem, $A_1 F_{12} = A_2 F_{21}$

$$F_{21} = \frac{A_1}{A_2}$$

$$F_{21} = \frac{2 \times \frac{\pi}{4} d^2 + \pi dH}{6L^2} = \frac{\frac{\pi}{2} d^2 + \pi dH}{6L^2}$$

$$F_{22} = F_{ss} = 1 - \frac{\pi dh + \frac{\pi}{2} d^2}{6L^2}$$

Hence, the correct option is (D).

Question 44

[Manufacturing Engg.]

In an ideal orthogonal cutting experiment (see figure), cutting velocity $V = 1$ m/sec, the rake angle of the tool $\alpha = 5^\circ$, and the shear angle ϕ is known to be 45°

Applying the orthogonal cutting model, consider two shear planes PQ and RS closed to each other. As they approach the thin shear zone (shown as a thick line in the figure) plane RS gets sheared with respect to PQ, (point R1 shears to R2, and S1 shears to S2).

Assuming that the perpendicular distance between PQ and RS is $\delta = 25 \mu\text{m}$. What is the value of shear strain (in S^{-1}) that the material undergoes at the shear zone?

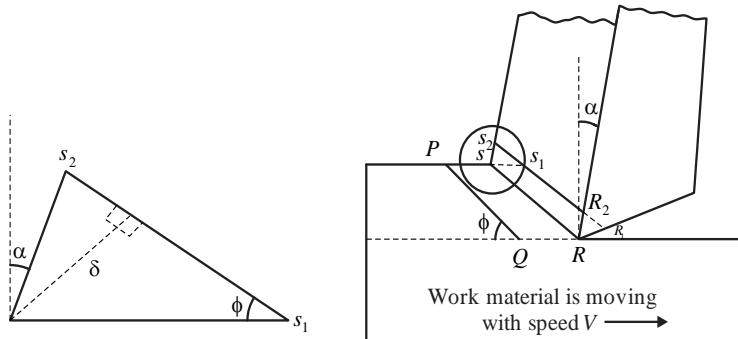

- (A) 1.84×10^4
(C) 0.71×10^4

- (B) 5.20×10^4
(D) 1.30×10^4

Ans. (B)

Sol. Given :

$$v = 1 \text{ m/sec}$$

$$\alpha = 5^\circ$$

$$\phi = 45^\circ$$

$$\Delta y = 25 \times 10^{-6} \text{ m}$$

$$v_s = v \times \frac{\cos \alpha}{\cos(\phi - \alpha)} = 1 \times \frac{\cos 5^\circ}{\cos(45^\circ - 5^\circ)} = 1.3 \text{ m/sec}$$

$$\text{Shear strain rate} = \frac{1.3}{25 \times 10^{-6}} = 5.2 \times 10^4 \text{ per second}$$

Hence, the correct option is (B).

Question 45

A CNC machine has one of its linear positioning axes as shown in figure. Consisting of a motor rotating a lead screw, which in turn moves a nut horizontally on which a table is mounted. The motor moves in discrete rotational steps of 50 steps per revolution. The pitch of the screw is 5 mm and the total horizontal traverse length of the table is 100 mm. What is the total number of controllable locations at which the table can be positioned on this axis?

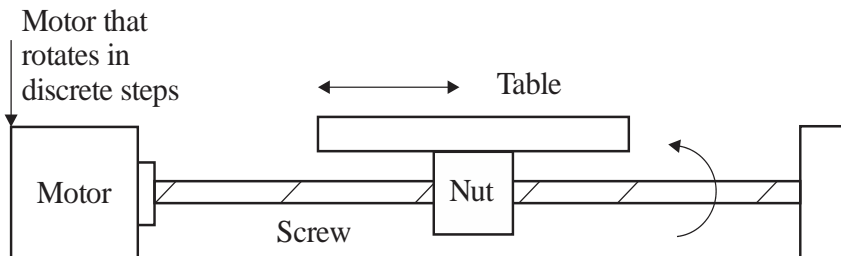

- (A) 5000
(C) 1000

- (B) 2
(D) 200

Ans. (C)

Sol. Given : Pitch of screw (p) = 5 mm

Length of table = 10 mm

Motor revolution (N) = 50 steps

$$1 \text{ pulse} = \frac{1}{50}$$

$$\therefore BLU = p \times \frac{1}{50} = 5 \times \frac{1}{50} = 0.1 \text{ mm}$$

$$0.1 \text{ mm} = 1 \text{ pulse}$$

$$1 \text{ mm} = 10 \text{ pulse}$$

$$100 \text{ mm movement of horizontal table} = 10 \times 100 = 1000 \text{ pulse}$$

Hence, the correct option is (C).

Question 46

[Strength of Materials]

Cylindrical bars P and Q have identical length and radii, but are composed of different linear elastic materials. The Young's modulus and coefficient of thermal expansion of Q are twice the corresponding values of P. Assume the bars to be perfectly bonded at the interface, and their weights to be negligible. The bars are held between rigid supports as shown in figure and the temperature is raised by ΔT . Assume that the stress in each bar is homogeneous and uniaxial. Denote the magnitudes of stress in P and Q by σ_1 and σ_2 respectively.



Which of the following statement is/are correct

- (A) Interface between P and Q moves to left after heating
- (B) Interface between P and Q moves to right after heating
- (C) $\sigma_1 < \sigma_2$
- (D) $\sigma_1 = \sigma_2$

Ans. (A) & (D)

Sol.

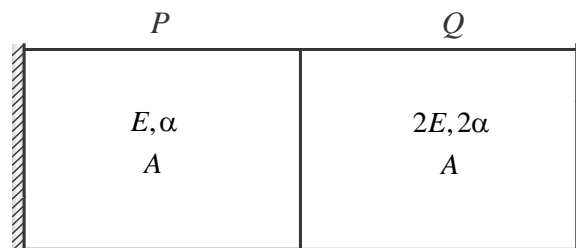

According to question,

Where, E = Modulus of elasticity, α = Coefficient of thermal expansion.

As we know from question bar is fixed in both sides

Apply $\Sigma F_x = 0$,

$$\text{Stress in bar (P)} = \frac{R}{A} = \sigma_1 \dots\dots(i)$$

$$\text{Stress in bar (Q)} = \frac{R}{A} = \sigma_2 \dots\dots(ii)$$

From equations (i) and (ii),

$$\sigma_1 = \sigma_2$$

So, option (D) will correct

Apply compatibility equation

$$\Delta l_{\text{total}} = 0$$

$$l\alpha\Delta T - \frac{\sigma_1 l}{E} + 2l\alpha\Delta T - \frac{\sigma_1 l}{2E} = 0$$

$$\frac{3\sigma_1 l}{2E} = 3l\alpha\Delta T$$

$$\sigma_1 = 2E\alpha\Delta T$$

$$\text{Change in length in bar } P = l\alpha\Delta - \frac{\sigma_1 l}{E} = l\alpha\Delta T - 2l\alpha\Delta T = -l\alpha\Delta T$$

Minus sign shows that bar P compress so this interface will moves towards left.

Hence the correct option are (A) and (D).

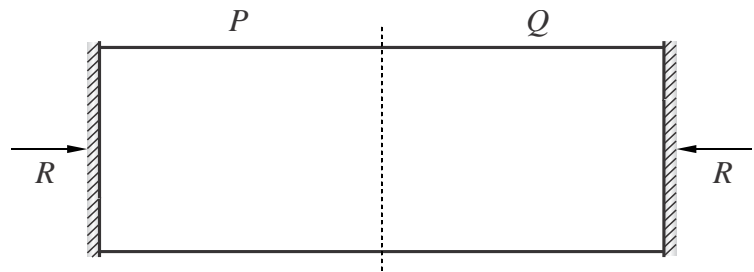

Question 47

[Heat Transfer]

A very large metal plate of thickness d and thermal conductivity k is cooled by a stream of air at temperature $T_\infty = 300$ K with a heat transfer coefficient h , as shown in the figure. The centerline temperature of the plate is T_p . In which of the following case(s) can the lumped parameter model be used to study the heat transfer in the metal plate?

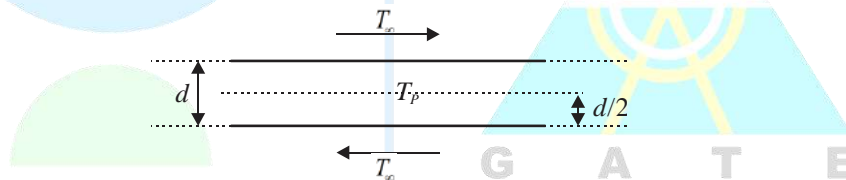

- (A) $h = 10 \text{ Wm}^{-2}\text{K}^{-1}$, $k = 100 \text{ Wm}^{-1}\text{K}^{-1}$, $d = 1 \text{ mm}$, $T_p = 350 \text{ K}$
- (B) $h = 100 \text{ Wm}^{-2}\text{K}^{-1}$, $k = 100 \text{ Wm}^{-1}\text{K}^{-1}$, $d = 1 \text{ m}$, $T_p = 325 \text{ K}$
- (C) $h = 100 \text{ Wm}^{-2}\text{K}^{-1}$, $k = 1000 \text{ Wm}^{-1}\text{K}^{-1}$, $d = 1 \text{ mm}$, $T_p = 325 \text{ K}$
- (D) $h = 1000 \text{ Wm}^{-2}\text{K}^{-1}$, $k = 1 \text{ Wm}^{-1}\text{K}^{-1}$, $d = 1 \text{ m}$, $T_p = 350 \text{ K}$

Ans. (A) & (C)

Sol. As we know,

To apply lumped analysis, $Bi \leq 0.1$

$$Bi = \frac{hL_c}{k}$$

Where, L_c = Characteristic length, h = Heat transfer coefficient in ($\text{W}/\text{m}^2\text{k}$),

k = Thermal conductivity in (W/mk)

$$L_c = \frac{v}{A_s}$$

For large plate, $L_c = \frac{d \times L \times L}{2L^2}$

$$L_c = \frac{d}{2}$$

So, check all options

Option (A) :

$$Bi = \frac{10 \times 0.5 \times 10^{-3}}{100} = 0.5 \times 10^{-4}$$

Option (B) :

$$Bi = \frac{100 \times 0.5}{100} = 0.5$$

Option (C) :

$$Bi = \frac{100 \times 0.5 \times 10^{-3}}{1000} = 5 \times 10^{-5}$$

Option (D) :

$$Bi = \frac{1000 \times 0.5}{1} = 500$$

Hence, the correct options are (A) and (C).

Question 48

The smallest perimeter that a rectangle with area of 4 square units can have is _____ units. (Answer in integer)

Ans. 7.999 to 8.001

Sol. Area of rectangle = $l \times b = 4$

$$\text{Perimeter of rect} = 2(l + b) = 2\left(l + \frac{4}{l}\right)$$

Two numbers : l and $\frac{4}{l}$

AM \geq GM

$$\frac{\left(l + \frac{4}{l}\right)}{2} \geq \left(l \times \frac{4}{l}\right)^{\frac{1}{2}}$$

$$\left(l + \frac{4}{l}\right) \geq 2 \times 2$$

$$\left(l + \frac{4}{l}\right) \geq 4$$

$$\therefore \left(l + \frac{4}{l}\right)_{\min} = 4$$

[Engineering Mathematics]

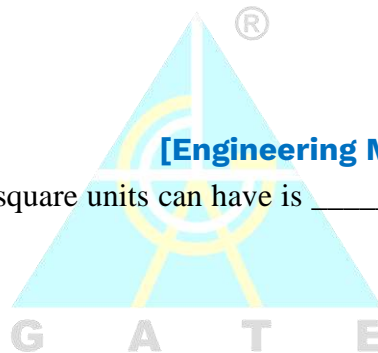

When $l = 2$ units,

$$(\text{perimeter})_{\min} = 2\left(l + \frac{4}{l}\right) = 2 \times 4 = 8 \text{ units.}$$

Hence, the correct answer is 8.

Question 49

[Engineering Mathematics]

Consider the second order linear ordinary differential equation $x^2 \frac{d^2 y}{dx^2} + x \frac{dy}{dx} - y = 0, x \geq 1$ with initial

condition $y(x=1) = 6, \left. \frac{dy}{dx} \right|_{x=1} = 2$. The value of y at $x = 2$ equals _____ (Answer in integer).

Ans. 8.999 to 9.001

Sol. $(x^2 D^2 + nD - 1)y = 0$

$$x = e^t \Leftrightarrow 2 = \ln x$$

$$(\theta(\theta-1) + \theta - 1)y = 0$$

$$(\theta^2 - \theta + \theta - 1)y = 0$$

$$(\theta^2 - 1)y = 0$$

AE is $m^2 - 1 = 0 \quad m = \pm 1 \quad CF = c_1 e^{-2} + C_2 e^2$

Solution is, $y = \frac{C_1}{x} + C_2 x$

$$y(1) = 6$$

$$6 = C_1 + C_2$$

$$y' = \frac{-C_1}{x^2} + C_2$$

$$y'(1) = 2$$

$$2 = -C_1 + C_2$$

From equations (ii) and (iv),

$$C_1 = 2, \quad C_2 = 4$$

$$y = \frac{2}{x} + 4x$$

When $x = 2, y = \frac{2}{2} + 4(2) = 1 + 8 = 9$

$$y(2) = 9$$

Hence, the correct answer is 9.

Question 50

[Engineering Mathematics]

The initial value problem $\frac{dy}{dt} + 2y = 0, y(0) = 1$ is solved numerically using the forward Euler's method with a constant and positive time step of Δt .

Let y_n represent the numerical solution obtained after n steps. The condition $|y_{n+1}| \leq |y_n|$ is satisfied if and only if Δt does not exceed _____. (Answer in integer)

Ans. 0.999 to 1.001

Sol. Given : $\frac{dy}{dt} + 2y = 0$, $y(0) = 1$

$$t_0 = 0$$

$$h = \Delta t = \text{positive}$$

$$y_0 = 1$$

$$\frac{dy}{dt} = -2y$$

$$f(t, y) = -2y$$

$$y_{n+1} = y_n + hf(t_n, y_n)$$

$$y_{n+1} = y_n + \Delta t(-2y_n)$$

$$t_{n+1} = t_n + \Delta t$$

$$y_{n+1} = y_n(1 - 2\Delta t)$$

$$\frac{y_{n+1}}{y_n} = 1 - 2\Delta t$$

$$\frac{|y_{n+1}|}{|y_n|} \leq 1$$

$$\Rightarrow |1 - 2\Delta t| \leq 1$$

$$-1 \leq 1 - 2\Delta t \leq 1$$

$$-2 \leq -2\Delta t \leq 0$$

$$0 \leq 2\Delta t \leq 2$$

$$0 \leq \Delta t \leq 1$$

Hence, the correct answer is 1.

Question 51

[Material Science]

The atomic radius of a hypothetical face-centered cubic (FCC) metal is $\left(\frac{\sqrt{2}}{10}\right)$ mm. The atomic weight of the metal is 24.092 g/mol. Taking Avogadro's number to be 6.023×10^{23} atoms/mol. The density of the metal is _____ kg/m³. (Answer in integer)

Ans. 2499.999 to 2500.001

Sol. Given : Atomic radius, $r = \frac{\sqrt{2}}{10}$ nm

Where, $m = 24.092$ g/mol, 6.023×10^{23} atoms/mol

To find : Density of metal in kg/m^3 .

$$\rho = \frac{N_{av} \times \text{At. weight}}{6 \times 0.23 \times 10^{23} \times \text{Volume of unit cell } (a^3)}$$

For FCC, $4r = \sqrt{2}a \Rightarrow a = \frac{4r}{\sqrt{2}}$ and $N_{av} = 2$

$$\rho = \frac{4 \times 24.092 \times 10^{-3}}{6.023 \times 10^{23} \times \left(\frac{4r}{\sqrt{2}}\right)^3} = \frac{4 \times 24.092 \times 10^{-3}}{6.023 \times 10^{23} \times \left(\frac{4}{\sqrt{2}} \times \frac{\sqrt{2}}{10} \times 10^{-9}\right)^3} \text{ kg/m}^3$$

$$\rho = \frac{4 \times 24.092 \times 10^{-3}}{6.023 \times 10^{23} \times (0.4)^3 \times 10^{-27}} = \frac{4 \times 24.092}{6.023 \times (0.4)^3} = 2500 \text{ kg/m}^3$$

Hence, the correct answer is 2500.

Question 52

[Material Science]

A steel sample with 1.5 wt% carbon (no other alloying elements present) is slowly cooled from 1100°C to just below the eutectoid temperature (723°C). A part of the iron-cementite phase diagram is shown in the figure. The ratio of the pro-eutectoid cementite content to the total cementite content in the micro structure that develops just below the eutectoid temperature is _____.

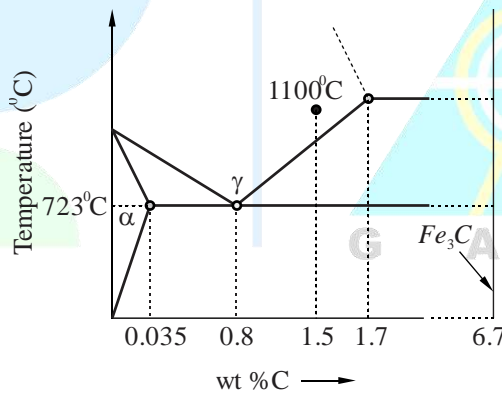

Ans. 0.53 to 0.55

Sol.

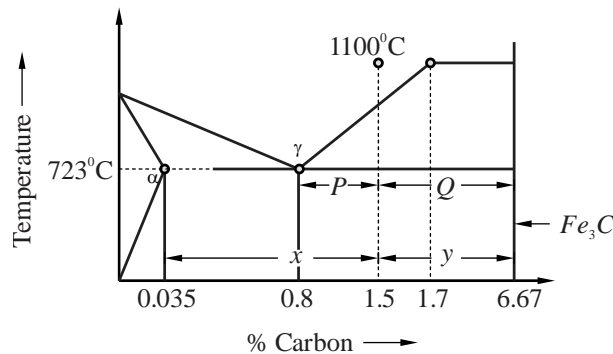

$$\text{Pro-eutectoid cementite } (\text{Fe}_3\text{C}') = \frac{P}{P+Q} = \frac{1.5-0.8}{6.67-0.8} = 0.119$$

$$\text{Total cementite } (Fe_3C) = \frac{x}{x+y} = \frac{1.5-0.035}{6.67-0.035} = 0.22$$

$$\therefore \text{Ratio of } \frac{Fe_3C'}{Fe_3C} = \frac{0.119}{0.22} = 0.54$$

Hence, the correct answer is 0.54.

Question 53**[Manufacturing Engg.]**

A part, produced in high volumes, is dimensioned as shown. The machining process making this part is known to be statistically in control based on sampling data. The sampling data showed that D_1 follows a normal distribution with a mean of 20 mm and standard deviation of 0.3 mm, while D_2 follows a normal distribution with a mean of 35 mm and standard deviation of 0.4. An inspection of dimension C is carried out in a sufficiently large number of parts.

To be considered under six-sigma process control, the upper limit of dimension C should be _____ mm. (Rounded off to one decimal place)

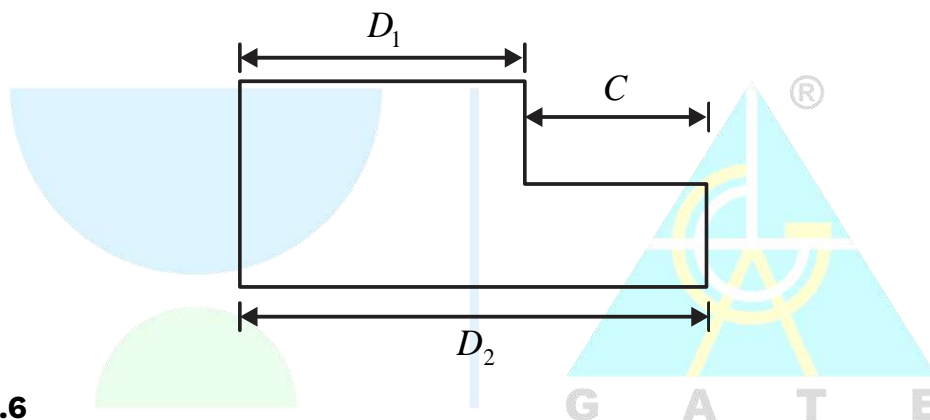
**Ans. 16.4 to 16.6**

Sol. Given : $D_1 = 20$ mm, $\sigma_1 = 0.3$, $D_2 = 35$ mm and $\sigma_2 = 0.4$.

$$\text{Mean value of } C = D_2 - D_1 = 35 - 20 = 15 \text{ mm}$$

$$\text{Standard deviation for last part} = \sqrt{\sigma_2^2 - \sigma_1^2} = \sqrt{0.4^2 - 0.3^2}$$

$$\text{Standard deviation} = 0.2645$$

$$\text{Upper limit} = 15 + 6 \times 0.2645 = 16.587 \text{ mm}$$

Hence, the correct answer is 16.587.

Question 54**[Manufacturing Engg.]**

A coordinate measuring machine (CMM) is used to determine the distance between Surface SP and Surface SQ of an approximately cuboidal shaped part. Surface SP is declared as the datum as per the engineering drawing used for manufacturing this part. The CMM is used to measure four points P1, P2, P3, P4 on Surface SP, and four points Q1, Q2, Q3, Q4 on Surface SQ as shown. A regression procedure is used to fit the necessary planes.

The distance between the two fitted planes is _____ mm. (Answer in integer)

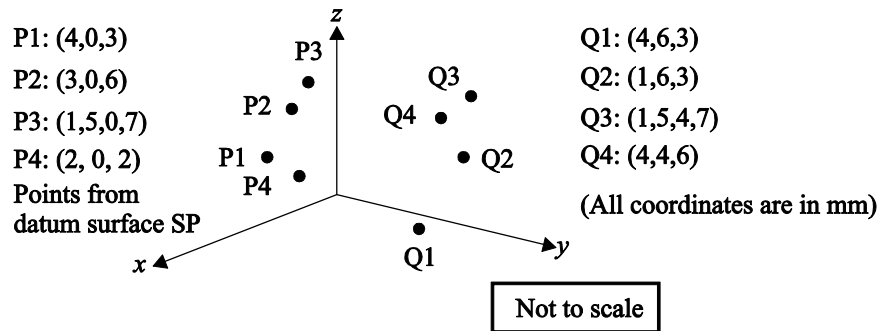
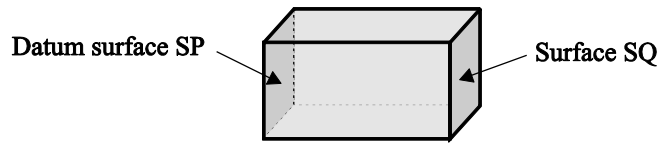

Ans. 4.999 to 5.001

Sol. Y-coordinate of point P1, P2, P3 and P4 is zero.

Hence, plane fitted between x-z plane.

Distance Q1 from x-z plane = (6 - 0) = 6 mm

Distance Q2 from x-z plane = (6 - 0) = 6 mm

Distance Q3 from x-z plane = (4 - 0) = 4 mm

Distance Q4 from x-z plane = (4 - 0) = 4 mm

Distance between two fitted plane = $\frac{6+6+4+4}{4} = 5$ mm

Hence, the correct answer is 5.

Question 55

A solid part (see figure) of polymer material is to be fabricated by additive manufacturing (AM) in square-shaped layers starting from the bottom of the part working upwards. The nozzle diameter of the AM machine is $a/10$ mm and the nozzle follows a linear serpentine path parallel to the sides of the square layers with a feed rate of $a/5$ mm/min.

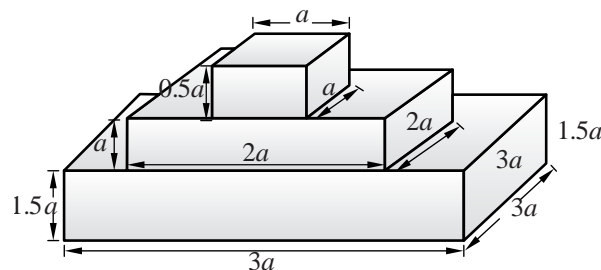

Ignore any tool path motions other than those involved in adding material, and any other delays between layers or the serpentine scan lines. The time taken to fabricate this part is _____ minutes. (Answer in integer)

Ans. 8999.999 to 9000.001

Sol. Given : Nozzle diameter = $\frac{a}{10}$ and Feed rate = $\frac{a}{5}$

If we consider the addition of material as wire.

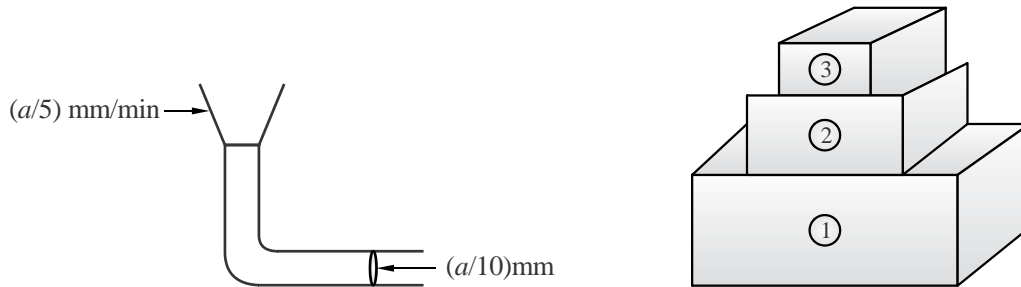

For block 1
Side view :

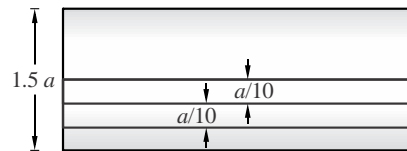

$$\text{Number of layers to be deposited} \Rightarrow \frac{1.5a}{\frac{1}{10}} = 15 \text{ layers}$$

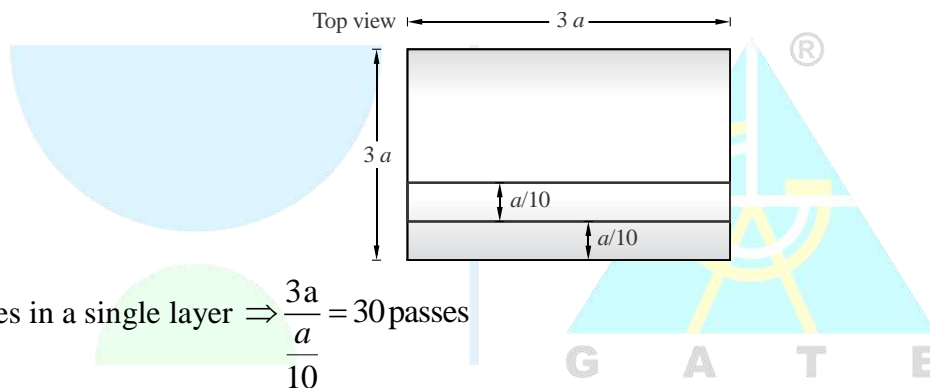

$$\text{No. of passes in a single layer} \Rightarrow \frac{3a}{\frac{a}{10}} = 30 \text{ passes}$$

$$\text{Time for one pass} \Rightarrow \frac{3a}{\frac{a}{5}} = 15 \text{ min}$$

So, time for one layer = $15 \times 30 = 450 \text{ min/layer}$

Time for block (1) = $450 \times 15 = 6750 \text{ min}$

Similarly, for block (2) = 2000 min

For block (3) = 250 min

Total time = $6750 + 2000 + 250 = 9000 \text{ min.}$

Hence, the correct answer is 9000.

Question 56

[Manufacturing Engg.]

An optical flat is used to measure the height difference between a reference slip gauge A and a slip gauge B. Upon viewing the optical flat using a monochromatic light of wavelength $0.5 \mu\text{m}$. 12 fringes were observed over a length of 15 mm of gauge B. If the gauges are placed 45 mm apart, the height difference of the gauge is _____ μm . (Answer in integer)

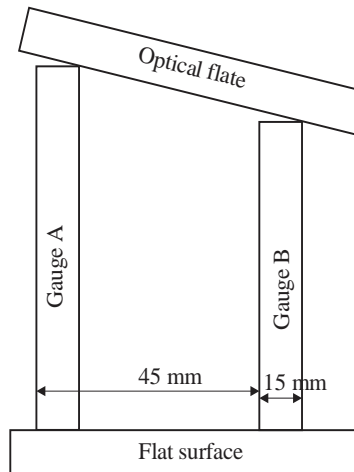

Ans. 8.999 to 9.001

Sol.
$$\Delta h = \frac{n\lambda l}{2} = \frac{1.5 \times 0.5 \times 10^{-6} \times 4.5}{2}$$

$$\Delta h = 9 \mu\text{m}$$

Hence, the correct answer is 9.

Question 57

Ignoring the small elastic region, the true stress-strain variation of material beyond yielding follows the equation $\sigma = 400\varepsilon^{0.3}$ MPa. The engineering ultimate tensile strength value of this material is _____ MPa.

Ans. 206.4 to 206.6

Sol. Given : $\sigma = 400\varepsilon^{0.3}$

For UTS, $dF = 0$

$$\therefore \sigma = \frac{F}{A}$$

$$\therefore F = \sigma A$$

$$dF = 0$$

$$\sigma dA + Ad\sigma = 0$$

$$\frac{d\sigma}{\sigma} = -\frac{dA}{A}$$

$$\frac{d\sigma}{\sigma} = \varepsilon$$

$$\therefore \varepsilon = n \text{ [at true UTS]}$$

$$\sigma_T = 400 \times 0.3^{0.3} = 278.73 \text{ MPa}$$

$$\sigma_T = \sigma_\varepsilon (1 + e) \quad \dots(\text{ii})$$

$$\therefore \varepsilon = \ln(1 + e)$$

$$1 + e = \exp(\varepsilon) = 1.349$$

[Manufacturing Engg.]

... (i) G A T E

From equation (ii),

$$\sigma_\varepsilon = \frac{\sigma_T}{1+e} = \frac{278.73}{1.349} = 206.48 \text{ MPa}$$

Hence, the correct answer is 206.48.

Question 58

[Engineering Mechanics]

The area moment of inertia about the y-axis of a linearly tapered section shown in the figure is _____ m^4 . (Answer in integer)

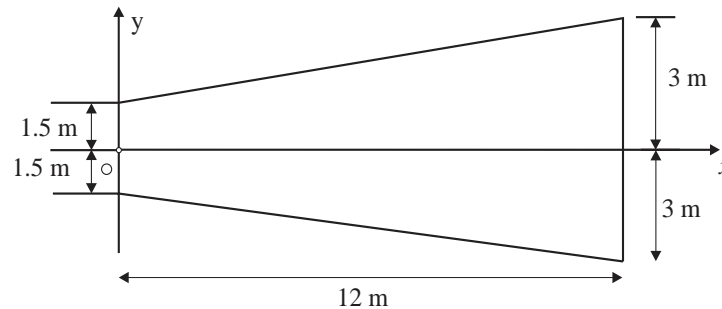

Ans. 3023.999 to 3024.001

Sol. $I_y = (I_y)_{\text{Rect}} + 2I_{\text{triangle}}$

$$I_y = \frac{3 \times 12^3}{3} + 2 \times \left[\frac{1.5 \times 12^3}{36} + \frac{1}{2} \times 12 \times 1.5 \times \left(\frac{2 \times 12}{3} \right)^2 \right] = 3024 \text{ m}^4$$

Hence, the correct option is 3024.

Question 59

[Strength of Materials]

A cylindrical bar has a length $L = 5 \text{ m}$ and cross section area $S = 10 \text{ m}^2$. The bar is made of a linear elastic material with a density $\rho = 2700 \text{ kg/m}^3$ and Young's modulus $E = 70 \text{ GPa}$. The bar is suspended as shown in the figure and is in a state of uniaxial tension due to its self-weight.

The elastic strain energy stored in the bar equals _____ J. (Rounded off to two decimal places)

Take the acceleration due to gravity as $g = 9.8 \text{ m/s}^2$.

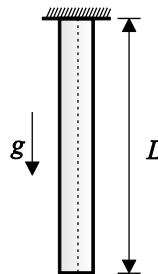

Ans. 2.00 to 2.16

Sol. Strain energy $= \frac{1}{2} (\sigma \varepsilon) \times \text{Volume}$

$$\text{Strain energy} = \frac{1}{2} \left(\frac{\sigma^2}{E} \right) \times \text{Volume}$$

$$\sigma = \frac{(\rho Ax)g}{A} = \rho xg$$

$$du = \frac{\rho^2 x^2 g^2}{2E} \times Adx$$

$$U = \frac{\rho^2 g^2 A}{2E} \int_0^h x^2 dx = 2.088 \text{ J}$$

Hence, the correct answer is 2.088 J.

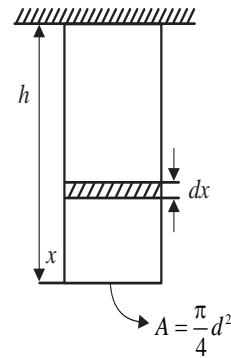
**Question 60****[Strength of Materials]**

A cylindrical transmission shaft of length 1.5 m and diameter 100 mm is made of a linear elastic material with a shear modulus of 80 GPa. While operating at 500 rpm, the angle of twist across its length is found to be 0.5 degrees. Power transmitted by the shaft is _____ kW. (Rounded off to two decimal places) Take $\pi = 3.14$

Ans. 237 to 240**Sol. Given :** Length (l) = 1.5 m, Diameter (d) = 100 mm, Shear modulus (G) = 80 GPaSpeed (N) = 500 r.p.m

$$\text{Angle of twist} = 0.5^\circ = \frac{0.5 \times \pi}{180} \text{ rad}$$

As we know,

$$\text{Torsion equation, } \frac{T}{j} = \frac{G\theta}{l}$$

$$T = \frac{\pi \times 80 \times 10^9 \times (0.1)^4 \times \pi \times 0.5}{32 \times 180 \times 1.5}$$

$$T = 4569.261 \text{ N-m}$$

$$\text{Power} = \frac{2\pi NT}{60} = \frac{2 \times \pi \times 500 \times 4569.261}{60} = 239.25 \text{ kW}$$

Hence, the correct answer is 239.25.

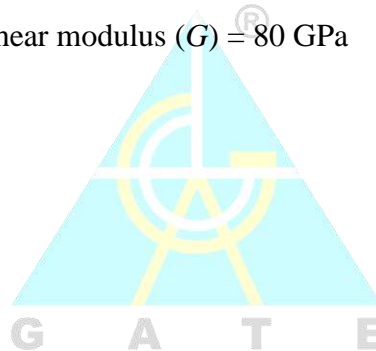
**Question 61****[Thermodynamics]**

Consider a mixture of two ideal gases, X and Y with molar masses $\overline{M}_x = 10 \text{ kg/kmol}$ and $\overline{M}_y = 20 \text{ kg/kmol}$ respectively. in a container. The total pressure in the container is 100 kPa, the total volume of the container is 10 m^3 and the temperature of the contents of the container is 300 K. If the mass of gas-X in the container is 2 kg, then the mass of gas-Y in the container is _____ kg. (Rounded off to one decimal place)

Assume that the universal gas constant is $8314 \text{ J kmol}^{-1} \cdot \text{K}^{-1}$

Ans. 3.9 to 4.1**Sol. Given :** $M_x = 10 \text{ kg/k-mol}$, $M_y = 20 \text{ kg/k-mol}$, $P_c = 100 \text{ kPa}$, $V_c = 10 \text{ m}^3$, $T_c = 300 \text{ k}$ and $m_x = 2 \text{ kg}$.

$$N_x = \frac{m_x}{M_x} = \frac{2}{10} = 0.2$$

$$P_x v = N_x \bar{R}T$$

$$P_x = \frac{0.2 \times 8.314 \times 300}{10} = 49.884 \text{ kPa}$$

$$P_y = 100 - 49.884 = 50.116 \text{ kPa}$$

$$P_y v = N_y \bar{R}T$$

$$50.116 \times 10 = N_y \times 8.314 \times 300$$

$$N_y = 0.201$$

$$m_y = N_y \times M_y = 0.2 \times 20 = 4.02 \text{ kg}$$

Hence, the correct answer is 4.02.

x & y

Question 62**[Fluid Mechanics]**

The velocity field of a certain 2-D flow is given by $V(x, y) = K(xi - yi)$, where $K = 2s^{-1}$. The coordinates x & y are in meters. Assume gravitational effect to be negligible.

If the density of the fluid is 1000 kg/m^3 and the pressure at the origin is 100 kPa the pressure at location $(2\text{m}, 2\text{m})$ is _____ kPa.

Ans. 84 (83.999 to 84.001)

Sol. Given : $v(x_i, y) = k(x_i - y_i)$

$$k = 2s^{-1}, \rho = 1000 \text{ kg/m}^3, p_1 = 100 \text{ kPa}$$

$$u = kx$$

$$v = -ky$$

$$v = \sqrt{(kx)^2 + (-ky)^2} = k\sqrt{x^2 + y^2}$$

$$\text{At origin } (0,0) = v_{(0,0)} = 0$$

$$\text{At } (2,2) = v_{(2,2)} = 2\sqrt{2^2 + 2^2} = 4\sqrt{2}$$

Applying Bernoulli's equation,

$$\frac{p_1}{\rho g} + \frac{v_1^2}{2g} + z_1 = \frac{p_2}{\rho g} + \frac{v_2^2}{2g} + z_2$$

$$\frac{p_2}{\rho g} = \frac{p_1}{\rho g} - \frac{v_2^2}{2g}$$

$$p_2 = p_1 - \frac{\rho v_2^2}{2} = 100 \times 10^3 - \frac{1000 \times (4\sqrt{2})^2}{2}$$

$$p_2 = 84000 = 84 \text{ kPa.}$$

Hence, the correct answer is 84.

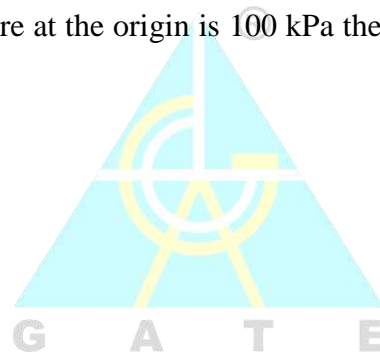

Question 63**[Fluid Mechanics]**

Consider a unidirectional fluid flow with velocity field is given by $V(x, y, z, t) = u(x, t)\hat{i}$, where $u(0, 1) = 1$. If spatially homogeneous density varies with time as $\rho(t) = 1 + 0.2e^{-t}$.

The value of $u(2, 1) =$ _____. (Round off to two decimal places). Assume all quantities to be dimensionless.

Ans. 1.14 (1.13 to 1.15)

Sol. $\rho \frac{\partial u}{\partial x} + \rho \frac{\partial v}{\partial y} + \rho \frac{\partial w}{\partial z} + \frac{\partial p}{\partial t} = 0$

$$(1 + 0.2e^{-t}) \left[\frac{\partial u}{\partial x} + \frac{\partial v}{\partial y} + \frac{\partial w}{\partial z} \right] - 0.2e^{-t} = 0$$

$$(1 + 0.2e^{-t}) \left[\frac{\partial u}{\partial x} \right] - 0.2e^{-t} = 0$$

$$(1 + 0.2e^{-t}) \left(\frac{\partial u}{\partial x} \right) = 0.2e^{-t}$$

$$\frac{\partial u}{\partial x} = \left(\frac{0.2e^{-t}}{1 + 0.2e^{-t}} \right)$$

$$u = \left(\frac{0.2e^{-t}}{1 + 0.2e^{-t}} \right) x + C$$

Since $u(0, t) = 1$ $c = 1$

$$u = \left(\frac{0.2 \times e^{-t}}{1 + 0.2e^{-t}} \right) \times 2 + 1$$

$$u = 1.1371 \text{ m/s}$$

$$u \approx 1.14 \text{ m/s}$$

Hence, the correct answer is 1.14.

Question 64**[Fluid Mechanics]**

The figure shows two fluids held by a hinged gate. The atmospheric pressure is $P_a = 100 \text{ kPa}$. The moment per unit width about the base of the hinge is _____. kNm/m . (Rounded off to one decimal place) Take the acceleration due to gravity to be $g = 9.8 \text{ m/s}^2$

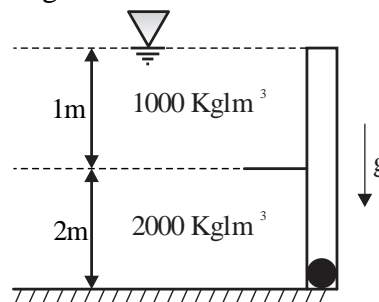
**Ans. 57.225 (57.1 to 57.3)**

Sol.

$$P_1 = \frac{(1000 \times 9.81 \times 1)}{1000}$$

$$P_1 = 9.81 \text{ KPa}$$

$$P_2 = P_1 + \rho_2 gh_2 = 9.81 + \frac{2000 \times 9.81 \times 2}{2}$$

$$P_2 = 49.05 \text{ KPa}$$

$$\bar{x} = \left(\frac{P_2 + 2P_1}{P_1 + P_2} \right) \times \frac{2}{3} = \frac{7}{9}$$

$$F_1 = \frac{1}{2} \times P_1 \times 1 \times 1$$

$$F_2 = (P_1 + P_2) \times \frac{2}{2} = 58.86 \text{ KN}$$

$$M_0 = F_1 \times \frac{7}{3} + F_2 \times \bar{x}$$

$$M_0 = 57.225 \text{ KN-m}$$

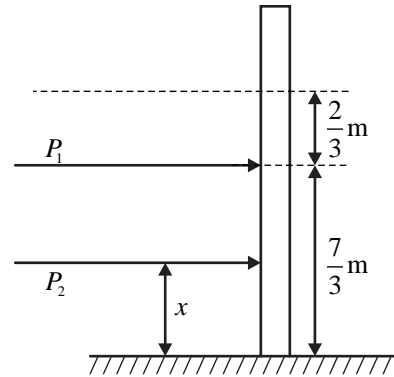

Hence, the correct answer is 57.225.

Question 65

[Fluid Mechanics]

An explosion at time $t = 0$ releases energy E at the origin in a space filled with a gas density (ρ). Subsequently, a hemispherical blast wave propagates radially outwards as shown in the figure. Let R denotes the radius of the front of the hemispherical blast wave. The radius R follows the relationship: $R = k \times t^a E^b \rho^c$ where k is a dimensionless constant. The value of exponent a is _____. (Rounded off to one decimal place)

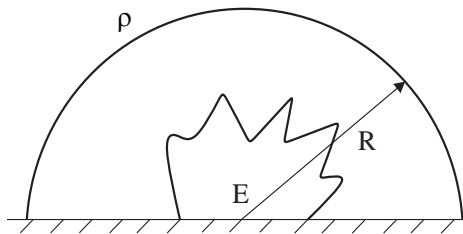

Ans. 0.39 to 0.41

Sol. E = Energy, ρ = Gas density, R = Radius, t = Time

Given : $R = kt^a E^b \rho^c$

Where, k is a dimensionless constant writing down in [MLT] dimension form each term.

$$[M^0 L^1 T^0] = [M^0 L^0 T^1]^a [ML^2 T^{-2}]^b [ML^{-3} T^0]^c$$

Comparing powers of M, L and T on both sides.

$$b + c = 0$$

$$b = -c \quad \dots(i)$$

$$1 = 2b - 3c$$

$$1 = -2c - 3c$$

$$c = -\frac{1}{5}$$

$$b = \frac{1}{5}$$

$$a - 2b = 0$$

$$a = 2b$$

$$a = \frac{2}{5}$$

$$a = 0.4$$

Hence, the correct answer is 0.4.

□□□

