

**General Aptitude****Q.1 to Q.5 Carry One mark each****Question 1**

Kavya _____ go to work yesterday as she _____ feeling well.

Select the most appropriate option to complete the above sentence.

- (A) didn't; isn't (B) wouldn't; wasn't
(C) wasn't; wasn't (D) couldn't; wasn't

Ans. (D)

Question 2

Good : Evil :: Genuine : _____

Select the most appropriate option to complete the analogy.

- (A) Counterfeit (B) Contraband
(C) Counterfoil (D) Counterpart

Ans. (A)

Question 3**[Numerical Ability – Number System & Series]**

The relationship between two variables x and y is given by $x + py + q = 0$ and is shown in the figure. Find the values of p and q .

Note : The figure shown is representative.

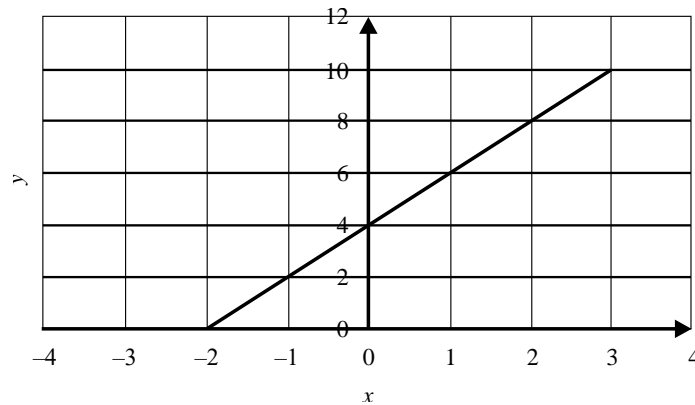

- (A) $p = -\frac{1}{2}; q = 2$ (B) $p = 2; q = -2$
(C) $p = \frac{1}{2}; q = 4$ (D) $p = 2; q = 4$

Ans. (A)

Question 4**[Verbal Ability – Syllogism]**



Each row of Column-I has three items and each item is represented by a circle in Column-II. The arrangement of circles in Column-II represents the relationship among the items in Column-I.

Identify the option that has the most appropriate match between Column-I and Column-II.

Note : The figures shown are representative.

Column-I		Column-II	
(1)	Animals, Zebra, Giraffe	(P)	
(2)	Director, Producer, Actor	(Q)	
(3)	Word, Sentence, Novel	(R)	
(4)	Pianist, Guitarist, Instrumentalist	(S)	

(A) (1)-(Q); (2)-(P); (3)-(S); (4)-(R)

(B) (1)-(Q); (2)-(R); (3)-(S); (4)-(P)

(C) (1)-(S); (2)-(P); (3)-(R); (4)-(Q)

(D) (1)-(R); (2)-(S); (3)-(Q); (4)-(P)

Ans. (B)

Question 5

[Numerical Ability]

What is the value of $\left(\frac{3^{81}}{27^4}\right)^{\frac{1}{3}}$?

(A) 3^{13}

(B) 3^{96}

(C) 3^{23}

(D) 3^{69}

Ans. (C)

Q.6 to Q.10 Carry Two marks each

Question 6

Identify the option that has the most appropriate sequence such that a coherent paragraph is formed :

P. It is because deer, like most of the animals that tigers normally prey on, run much faster! It simply means, another day of empty stomach for the big cats.

Q. Tigers spend most of their life searching for food.



- R. If they trace the scent of deer, tigers follow the trail, chase the deer for a mile or two in the dark, and yet may not catch them.
- S. For several nights, they relentlessly prowl through the forest, hunting for a trail that may lead to their prey.
- (A) $S \rightarrow P \rightarrow R \rightarrow Q$ (B) $R \rightarrow P \rightarrow S \rightarrow Q$
(C) $Q \rightarrow S \rightarrow R \rightarrow P$ (D) $P \rightarrow Q \rightarrow S \rightarrow R$

[Verbal Ability, Case Studies]

Ans. (C)

Question 7

In the given figure, EF and HJ are coded as 30 and 80, respectively. Which one among the given options is most appropriate for the entries marked (i) and (ii)?

[Numerical Ability, Number System & Series]

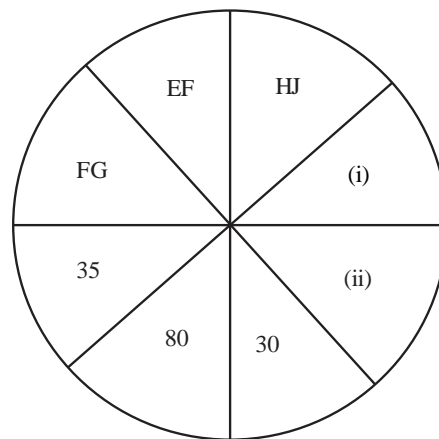

- (A) (i) EH; (ii) 40 (B) (i) JK; (ii) 36
(C) (i) EG; (ii) 42 (D) (i) PS; (ii) 14

Ans. (C)

Question 8

Scores obtained by two students P and Q in seven courses are given in the table below. Based on the information given in the table, which one of the following statements is INCORRECT?

P	22	89	50	45	78	60	39
Q	35	65	60	56	81	45	50

- (A) Average score of P is less than the average score of Q .
(B) Median score of P is same as the median score of Q .
(C) Difference between the maximum and minimum scores of P is greater than the difference between the maximum and minimum scores of Q .



(D) Median score and the average score of Q are same.

Ans. (B)

Question 9

Spheres of unit diameter are centered at (l, m, n) where $l, m,$ and n take every possible integer values.

The distance between two spheres is computed from the center of one sphere to the center of the other sphere. For a given sphere, x is the distance to its nearest sphere and y is the distance to its next nearest

sphere. The value of $\frac{y}{x}$ is :

(A) $2\sqrt{2}$

(B) $\frac{1}{\sqrt{2}}$

(C) $\sqrt{2}$

(D) 2

Ans. (C)

Question 10

In the triangle PQR , the lengths of PT and TR are in the ratio of 3:2.

ST is parallel to QR . Two semicircles are drawn with PS and PQ as diameters, as shown in the figure.

Which one of the following statements is true about the shaded area PQS ?

Note : The figure shown is representative.

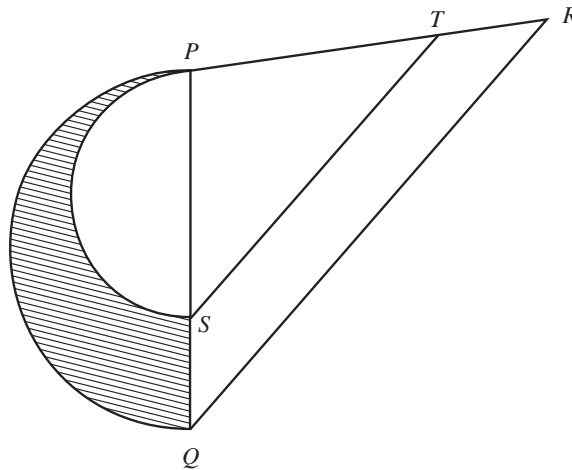

(A) The shaded $\frac{16}{9}$ times the area of the semicircle with the diameter PS .

(B) The shaded area is equal to the area of the semicircle with the diameter PS .

(C) The shaded area is $\frac{14}{9}$ times the area of the semicircle with the diameter PS .

(D) The shaded area is $\frac{14}{25}$ times the area of the semicircle with the diameter PQ .



Ans. (A)

Q.11 to Q.35 Carry One mark each

Question 11

Consider the set S of points $(x, y) \in \mathbb{R}^2$ which minimize the real valued function

$$f(x, y) = (x + y - 1)^2 + (x + y)^2$$

Which of the following statements is true about the set S ?

- (A) The number of elements in the set S is finite and more than one.
- (B) The number of elements in the set S is infinite.
- (C) The set S is empty.
- (D) The number of elements in the set S is exactly one.

Ans. (B)

Question 12

Let v_1 and v_2 be the two eigenvectors corresponding to distinct eigenvalues of a 3×3 real symmetric matrix. Which one of the following statements is true?

- (A) $v_1^T v_2 \neq 0$
- (B) $v_1^T v_2 = 0$
- (C) $v_1 + v_2 = 0$
- (D) $v_1 - v_2 = 0$

Ans. (B)

Question 13

Let $A = \begin{bmatrix} 1 & 1 & 1 \\ -1 & -1 & -1 \\ 0 & 1 & -1 \end{bmatrix}$, and $b = \begin{bmatrix} 1 \\ 3 \\ -1 \\ 3 \\ 0 \end{bmatrix}$. Then, the system of linear equations $Ax = b$ has

- (A) a unique solution.
- (B) infinitely many solutions.
- (C) a finite number of solutions.
- (D) no solution.

Ans. (B)

Question 14

[Engineering Mathematics, Linear Algebra]

Let $P = \begin{bmatrix} 2 & 1 & 0 \\ -1 & 0 & 0 \\ 0 & 0 & 1 \end{bmatrix}$ and let I be the identity matrix. Then P^2 is equal to

- (A) $2P - I$
- (B) P

(C) I (D) $P+I$

Ans. (A)

Question 15

Consider discrete random variables X and Y with probabilities as follows :

$$P(X = 0 \text{ and } Y = 0) = \frac{1}{4}$$

$$P(X = 1 \text{ and } Y = 0) = \frac{1}{8}$$

$$P(X = 0 \text{ and } Y = 1) = \frac{1}{2}$$

$$P(X = 1 \text{ and } Y = 1) = \frac{1}{8}$$

Given $X = 1$, the expected value of Y is

(A) $\frac{1}{4}$ (B) $\frac{1}{2}$ (C) $\frac{1}{8}$ (D) $\frac{1}{3}$

Ans. (C)

Question 16

Which one of the following statements is true about the small signal voltage gain of a MOSFET based single stage amplifier?

(A) Common source and common gate amplifiers are both inverting amplifiers

(B) Common source and common gate amplifiers are both non-inverting amplifiers

(C) Common source amplifier is inverting and common gate amplifier is non-inverting amplifier

(D) Common source amplifier is non-inverting and common gate amplifier is inverting amplifier

Ans. (C)

Question 17

Assuming ideal op-amps, the circuit represents a

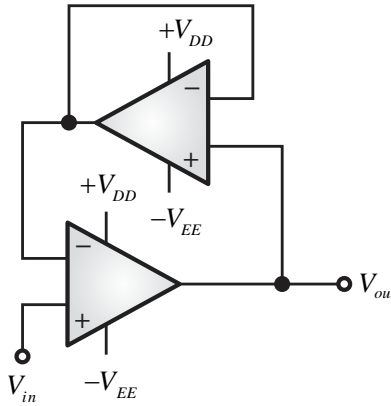

- (A) summing amplifier.
- (B) difference amplifier.
- (C) logarithmic amplifier.
- (D) buffer.

Ans. (D)

Question 18

The I-V characteristics of the element between the nodes X and Y is best depicted by

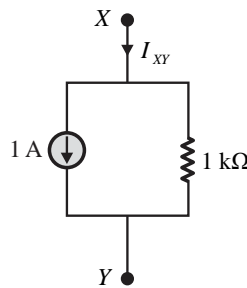

- (A)
- (B)
- (C)
- (D)

Ans. (B)

Question 19



A nullator is defined as a circuit element where the voltage across the device and the current through the device are both zero. A series combination of a nullator and a resistor of value, R , will behave as a

- (A) resistor of value R . (B) nullator.
(C) open circuit. (D) short circuit.

Ans. (B)

Question 20

Consider a discrete-time linear time-invariant (LTI) system S , where

$$y[n] = S\{x[n]\}$$

Let

$$S\{\delta[n]\} = \begin{cases} 1, & n \in \{0, 1, 2\} \\ 0, & \text{otherwise} \end{cases}$$

where $\delta[n]$ is the discrete-time unit impulse function. For an input signal $x[n]$, the output $y[n]$ is

- (A) $x[n] + x[n-1] + x[n-2]$ (B) $x[n-1] + x[n] + x[n+1]$
(C) $x[n] + x[n+1] + x[n+2]$ (D) $x[n+1] + x[n+2] + x[n+3]$

Ans. (A)

Question 21

Consider a continuous-time signal

$$x(t) = -t^2 \{u(t+4) - u(t-4)\}$$

where $u(t)$ is the continuous-time unit step function. Let $\delta(t)$ be the continuous-time unit impulse function. The value of

$$\int_{-\infty}^{\infty} x(t)\delta(t+3) dt$$

is

- (A) -9 (B) 9
(C) 3 (D) -3

Ans. (A)

Question 22

Selected data points of the step response of a stable first-order linear time-invariant (LTI) system are given below. The closest value of the time-constant, in sec, of the system is

Time (sec)	0.6	1.6	2.6	10	∞
Output	0.78	1.65	2.18	2.98	3

- (A) 1 (B) 2
(C) 3 (D) 4



Ans. (B)

Question 23

The Nyquist plot of a strictly stable $G(s)$ having the numerator polynomial as $(s-3)$ encircles the critical point -1 once in the anti-clockwise direction. Which one of the following statements on the closed-loop system shown in figure, is correct?

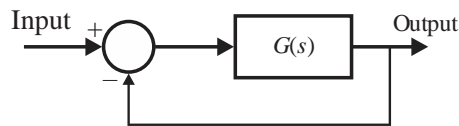

- (A) The system stability cannot be ascertained.
- (B) The system is marginally stable.
- (C) The system is stable.
- (D) The system is unstable.

Ans. (D)

Question 24

During a power failure, a domestic household uninterruptible power supply (UPS) supplies AC power to a limited number of lights and fans in various rooms. As per a Newton-Raphson load-flow formulation, the UPS would be represented as a

- (A) Slack bus
- (B) PV bus
- (C) PQ bus
- (D) PQV bus

Ans. (A)

Question 25

Which one of the following figures represents the radial electric field distribution E_R caused by a spherical cloud of electrons with a volume charge density, $\rho = -3\rho_0$ for $0 \leq R \leq a$ (both ρ_0 , a are positive and R is the radial distance) and $\rho = 0$ for $R > a$?

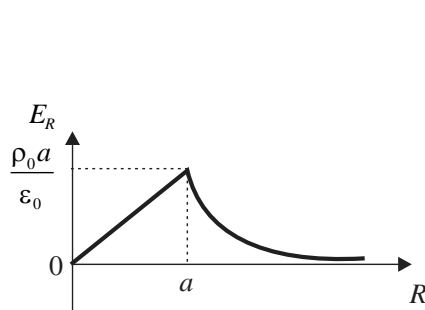

Fig. (i)

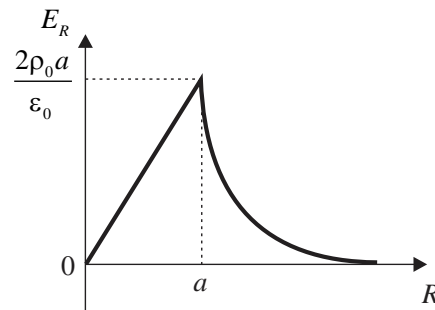

Fig. (ii)

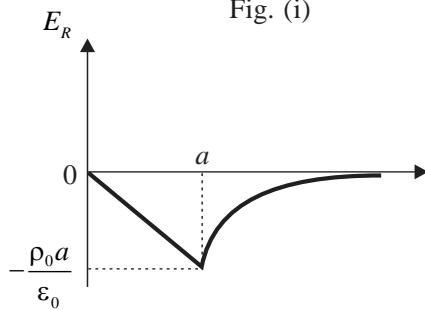

Fig. (iii)

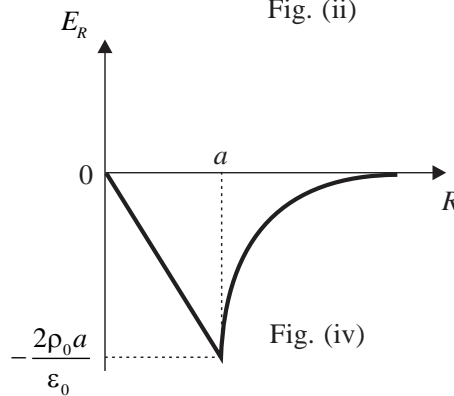

Fig. (iv)

(A) Fig. (i)

(B) Fig. (ii)

(C) Fig. (iii)

(D) Fig. (iv)

Ans. (C)

Question 26

The operating region of the developed torque (T_{em}) and speed (ω) of an induction motor drive is given by the shaded region OQRE in the figure. The load torque (T_L) characteristic is also shown. The motor drive moves from the initial operating point O to the final operating point S . Which one of the following trajectories will take the shortest time?

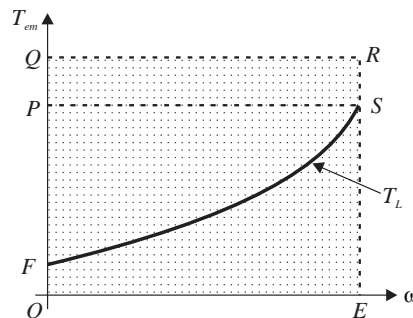

(A) $O-Q-R-S$

(B) $O-P-S$

(C) $O-E-S$

(D) $O-F-S$

Ans. (A)

Question 27



The input voltage $v(t)$ and current $i(t)$ of a converter are given by,

$$v(t) = 300 \sin(\omega t) \text{ V}$$

$$i(t) = 10 \sin\left(\omega t - \frac{\pi}{6}\right) + 2 \sin\left(3\omega t + \frac{\pi}{6}\right) + \sin\left(5\omega t + \frac{\pi}{2}\right) \text{ A}$$

where, $\omega = 2\pi \times 50$ rad/s. The input power factor of the converter is closest to

- (A) 0.845 (B) 0.867 (C) 0.887 (D) 1.0

Ans. (A)

Question 28

Instrument(s) required to synchronize an alternator to the grid is/are

- (A) Voltmeter (B) Wattmeter (C) Synchroscope (D) Stroboscope

Ans. (A, C)

Question 29

The open-loop transfer function of the system shown in the figure, is

$$G(s) = \frac{Ks(s+2)}{(s+5)(s+7)}$$

For $K \geq 0$, which of the following real axis point(s) is/are on the root locus?

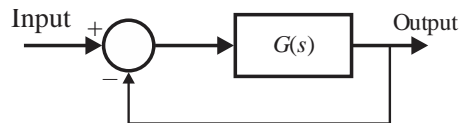

- (A) -1 (B) -4 (C) -6 (D) -10

Ans. (A, C)

Question 30

A continuous time periodic signal $x(t)$ is

$$x(t) = 1 + 2 \cos 2\pi t + 2 \cos 4\pi t + 2 \cos 6\pi t.$$

If T is the period of $x(t)$, then $\frac{1}{T} \int_0^T |x(t)|^2 dt = \underline{\hspace{2cm}}$ (Round off to the nearest integer).

Ans. 7 to 7

Question 31

The maximum percentage error in the equivalent resistance of two parallel-connected resistors of 100Ω and 900Ω with each having a maximum 5% error is _____% (Round off to nearest integer value).

Ans. 5 to 5

Question 32

Consider a distribution feeder, with R/X ratio of 5. At the receiving end, a 350 kVA load is connected. The maximum voltage drop will occur from the sending end to the receiving end, when the power factor of the load is _____ (Round off to three decimal places).



Ans. 0.975 to 0.985

Question 33

The bus impedance matrix of a 3-bus system (in pu) is

$$Z_{bus} = \begin{bmatrix} j0.059 & j0.061 & j0.038 \\ j0.061 & j0.093 & j0.066 \\ j0.038 & j0.066 & j0.110 \end{bmatrix}$$

A symmetrical fault (through a fault impedance of $j0.007$ pu) occurs at bus 2. Neglecting pre-fault loading conditions, the voltage at bus 1, during the fault is _____ pu (Round off to three decimal places).

Ans. 0.380 to 0.400

Question 34

[Power Electronics – Chopper]

In the circuit with ideal devices, the power MOSFET is operated with a duty cycle of 0.4 in a switching cycle with $I = 10$ A and $V = 15$ V. The power delivered by the current source, in W, is _____ (Round off to the nearest integer).

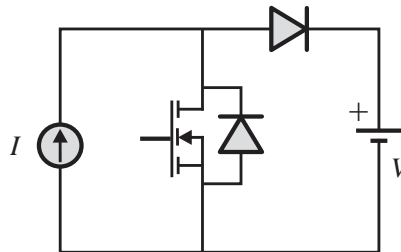

Ans. 90 to 90

Question 35

The induced emf in a 3.3 kV, 4 pole, 3-phase star connected synchronous motor is considered to be equal and in phase with the terminal voltage under no load condition. On application of a mechanical load, the induced emf phasor is deflected by an angle of 2° mechanical with respect to the terminal voltage phasor. If the synchronous reactance is 2Ω , and stator resistance is negligible, then the motor armature current magnitude, in ampere, during loaded condition is closest to, _____ (Round off to two decimal places).

Ans. 66.25 to 66.75

Q.36 to Q.65 Carry one mark each

Question 36

Let X and Y be continuous random variables with probability density functions $P_X(x)$ and $P_Y(y)$,

respectively. Further, let $Y = X^2$ and $P_X(x) = \begin{cases} 1, & x \in (0,1] \\ 0, & \text{otherwise} \end{cases}$.

Which one of the following options is correct?



$$(A) P_Y(y) = \begin{cases} \frac{1}{2\sqrt{y}}, & y \in (0,1] \\ 0, & \text{otherwise} \end{cases}$$

$$(B) P_Y(y) = \begin{cases} 1, & y \in (0,1] \\ 0, & \text{otherwise} \end{cases}$$

$$(C) P_Y(y) = \begin{cases} 1.5\sqrt{y}, & y \in (0,1] \\ 0, & \text{otherwise} \end{cases}$$

$$(D) P_Y(y) = \begin{cases} 2y, & y \in (0,1] \\ 0, & \text{otherwise} \end{cases}$$

Ans. (A)

Question 37

A Boolean function is given as

$$f = (\bar{u} + \bar{v} + \bar{w} + \bar{x}) \cdot (\bar{u} + \bar{v} + \bar{w} + x) \cdot (\bar{u} + v + \bar{w} + \bar{x}) \cdot (\bar{u} + v + \bar{w} + x)$$

The simplified form of this function is represented by

(A)

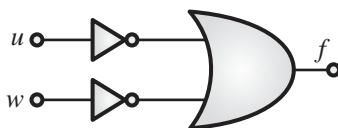

(B)



(C)

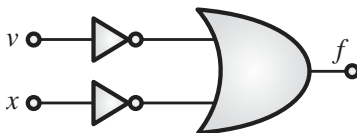

(D)

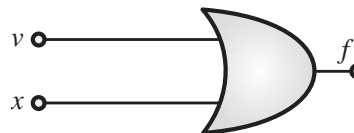

Ans. (A)

Question 38

In the circuit, I_{DC} is an ideal current source. The transistors M_1 and M_2 are assumed to be biased in saturation, wherein V_{in} is the input signal and V_{DC} is fixed DC voltage. Both transistors have a small signal resistance of r_{ds} and trans-conductance of g_m . The small signal output impedance of this circuit is

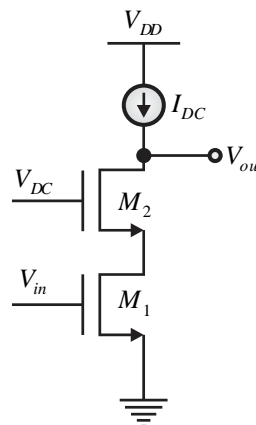



- (A) $2r_{ds}$ (B) $\frac{1}{g_m} + r_{ds}$ (C) $g_m r_{ds}^2 + 2r_{ds}$ (D) Infinity

Ans. (C)

Question 39

In the circuit, shown below, if the values of R and C are very large, the form of the output voltage for a very high frequency square wave input, is best represented by

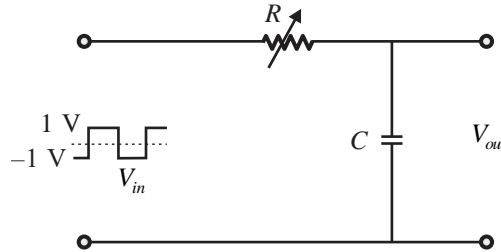

- (A) (B) (C) (D) (E)

Ans. (C)

Question 40

Let continuous-time signals $x_1(t)$ and $x_2(t)$ be

$$x_1(t) = \begin{cases} 1, & t \in [0,1] \\ 2-t, & t \in [1,2] \\ 0, & \text{otherwise} \end{cases} \quad \text{and} \quad x_2(t) = \begin{cases} t, & t \in [0,1] \\ 2-t, & t \in [1,2] \\ 0, & \text{otherwise} \end{cases}$$



Consider the convolution $y(t) = x_1(t) * x_2(t)$. Then $\int_{-\infty}^{\infty} y(t) dt$ is

- (A) 1.5 (B) 2.5 (C) 3.5 (D) 4

Ans. (A)

Question 41

Let $G(s) = \frac{1}{(s+1)(s+2)}$. Then the closed-loop system shown in the figure below, is

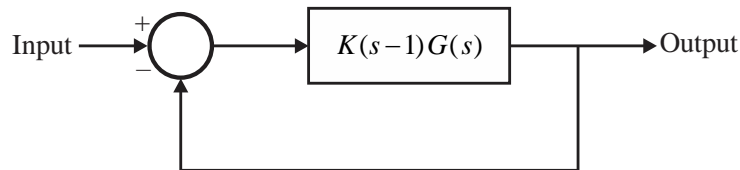

- (A) Stable for all $K > 2$ (B) Unstable for all $K > 2$
(C) Unstable for all $K > 1$ (D) stable for all $K > 1$

Ans. (B)

Sol. The given figure is shown below :

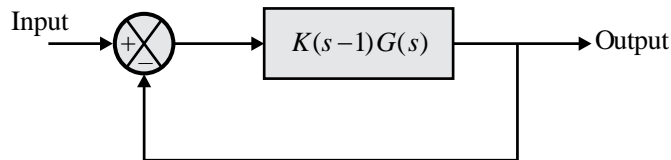

$$G(s) = \frac{1}{(s+1)(s+2)}$$

The characteristics is given by,

$$1 + G(s)H(s) = 0$$

$$1 + G(s) \cdot 1 = 0$$

$$1 + G(s) = 0$$

$$1 + K(s-1)G(s) = 0$$

$$1 + \frac{K(s-1)}{(s+1)(s+2)} = 0$$

$$(s+1)(s+2) + K(s-1) = 0$$

$$s^2 + 3s + 2 + Ks - K = 0$$

$$s^2 + (K+3)s + (2-K) = 0$$

Routh tabulation :



s^2	1	$(2-K)$
s^1	$(K+3)$	0
s^0	$(2-K)$	0

From the system to be stable, all roots must be in the left half of its s -plane, thus all the coefficients in the first column of Routh's tabulation must have the same sign. Therefore, first column of the Routh's table should be positive.

This leads to the following conditions.

$$(i) (K+3) > 0 \Rightarrow K > -3$$

$$(ii) (2-K) > 0 \Rightarrow 2 > K$$

The range of k for the system to be stable is

$$-3 < K < 2$$

And unstable for all $K > 2$.

Hence, the correct option is (B).

Question 42

The continuous-time unit impulse signal is applied as an input to a continuous-time linear time-invariant system S . The output is observed to be the continuous-time unit step signal $u(t)$. Which one of the following statements is true?

- (A) Every bounded input signal applied to S results in a bounded output signal.
- (B) It is possible to find a bounded input signal which when applied to S results in an unbounded output signal.
- (C) On applying any input signal to S , the output signal is always bounded.
- (D) On applying any input signal to S the output signal is always unbounded.

Ans. (B)

Question 43

The transformer connection given in the figure is part of a balanced 3-phase circuit where the phase sequence is "abc". The primary to secondary turns ratio is 2:1. If $(I_a + I_b + I_c = 0)$, then the relationship between I_A and I_{ad} will be

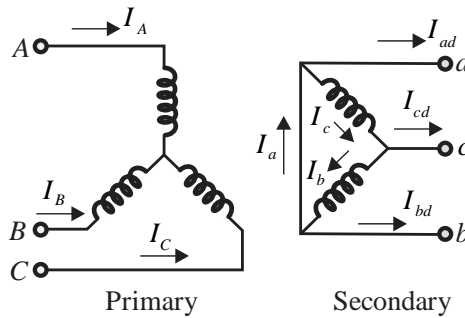

(A) $\frac{|I_A|}{|I_{ad}|} = \frac{1}{2\sqrt{3}}$ and I_{ad} lags I_A by 30° .

(B) $\frac{|I_A|}{|I_{ad}|} = \frac{1}{2\sqrt{3}}$ and I_{ad} leads I_A by 30° .

(C) $\frac{|I_A|}{|I_{ad}|} = 2\sqrt{3}$ and I_{ad} lags I_A by 30° .

(D) $\frac{|I_A|}{|I_{ad}|} = 2\sqrt{3}$ and I_{ad} leads I_A by 30° .

Ans. (A)

Question 44

A DC series motor with negligible series resistance is running at a certain speed driving a load, where the load torque varies as cube of the speed. The motor is fed from a 400 V DC source and draws 40 A armature current. Assume linear magnetic circuit. The external resistance, in Ω , that must be connected in series with the armature to reduce the speed of the motor by half, is closest to

- (A) 23.28 (B) 4.82 (C) 46.7 (D) 0

Ans. (A)

Question 45

A 3-phase, 400 V, 4 pole, 50 Hz star connected induction motor has the following parameters referred to the stator :

$$R_r' = 1\Omega, X_s = X_r' = 2\Omega$$

Stator resistance, magnetizing reactance and core loss of the motor are neglected. The motor is run with constant V/f control from a drive. For maximum starting torque, the voltage and frequency output, respectively, from the drive, is closest to,

- (A) 400 V and 50 Hz (B) 200 V and 25 Hz (C) 100 V and 12.5 Hz (D) 300 V and 37.5 Hz

Ans. (C)

Question 46

The 3-phase modulating waveforms ($v_a(t)$, $v_b(t)$ and $v_c(t)$), used in sinusoidal PWM in a Voltage Source Inverter (VSI) are

$$v_a(t) = 0.8\sin(\omega t) \text{ V}$$

$$v_b(t) = 0.8\sin\left(\omega t - \frac{2\pi}{3}\right) \text{ V}$$



$$v_c(t) = 0.8 \sin\left(\omega t + \frac{2\pi}{3}\right) \text{ V}$$

Where $\omega = 2\pi \times 40 \text{ rad/s}$ is the fundamental frequency. The modulating waveforms are compared with a 10 kHz triangular carrier whose magnitude varies between +1 and -1. The VSI has a DC link voltage of 600 V and feeds a star connected motor. The per phase fundamental RMS motor voltage, in volts, is closest to

- (A) 169.71 (B) 300.00 (C) 424.26 (D) 212.13

Ans. (A)

Question 47

An ideal sinusoidal voltage source $v(t) = 230\sqrt{2} \sin(2\pi \times 50t) \text{ V}$ feeds an ideal inductor L through an ideal SCR with firing angle $\alpha = 0^\circ$. If $L = 100 \text{ mH}$, then the peak of the inductor current, in ampere, is closest to

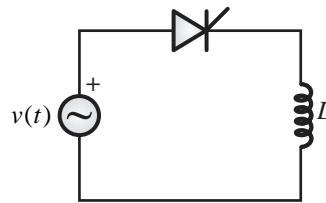

- (A) 20.71 (B) 0 (C) 10.35 (D) 7.32

Ans. (A)

Question 48

In the following circuit, the average voltage

$$V_0 = 400 \left(1 + \frac{\cos \alpha}{3}\right) \text{ V}$$

Where α is the firing angle. If the power dissipated in the resistor is 64 W, then the closest value of α in degrees is

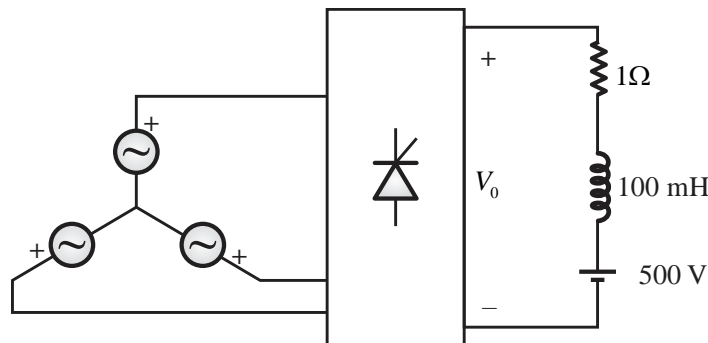

- (A) 35.9 (B) 46.4 (C) 41.4 (D) 0

Ans. (A)

Sol. Given :

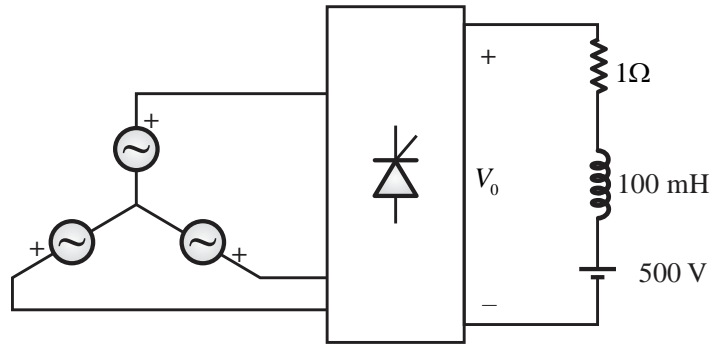

$$P_R = I_{or}^2 R = 64 \text{ W}$$

$$I_{or}^2 \times 1 = 64$$

$$I_{or} = 8 \text{ A} = I_0 \quad (\because \text{Current is ripple free})$$

$$V_0 = E + I_0 R$$

$$400 \left[1 + \frac{\cos \alpha}{3} \right] = 500 + 8 \times 1 = 508$$

$$\alpha = 35.9^\circ$$

Hence, the correct option is (A).

Question 49

In the system shown below, the generator was initially supplying power to the grid. A temporary LLLG bolted fault occurs at F very close to circuit breaker 1. The circuit breakers open to isolate the line. The fault self-clears. The circuit breakers reclose and restore the line. Which one of the following diagrams best indicates the rotor accelerating and decelerating areas?

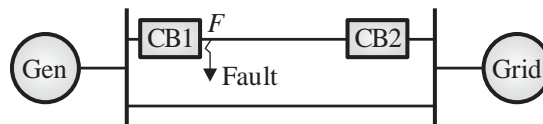

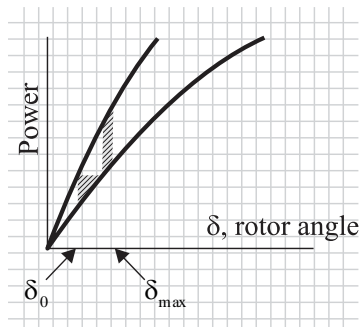

Fig. (i)

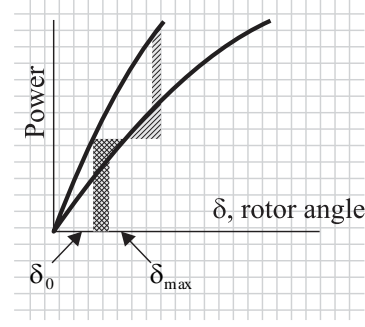

Fig. (ii)

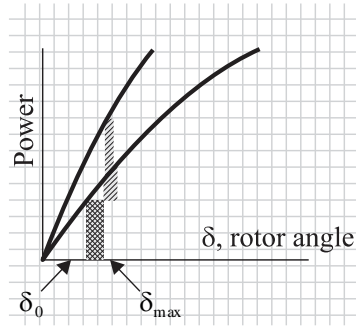

Fig. (iii)

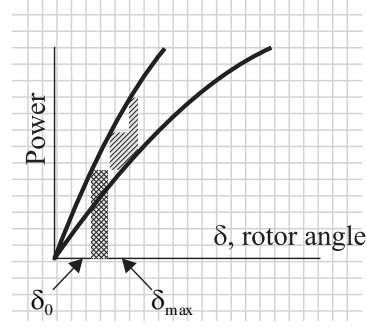

Fig. (iv)

(A) Fig. (i)

(B) Fig. (ii)

(C) Fig. (iii)

(D) Fig. (iv)

Ans. (B)

Question 50

An air filled cylindrical capacitor (capacitance C_0) of length L , with a and b as its inner and outer radii, respectively, consists of two coaxial conducting surfaces. Its cross-sectional view is shown in Fig. (i). In order to increase the capacitance, a dielectric material of relative permittivity ϵ_r is inserted inside 50% of the annular region as shown in Fig. (ii). The value of ϵ_r for which the capacitance of the capacitor in Fig. (ii), becomes $5C_0$ is

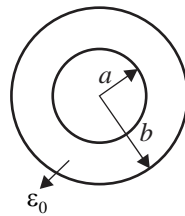

Fig. (i)

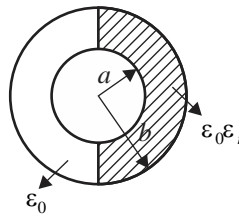

Fig. (ii)

(A) 4

(B) 5

(C) 9

(D) 10

Ans. (C)

Question 51



Let a_R be the unit radial vector in the spherical co-ordinate system. For which of the following value(s) of n , the divergence of the radial vector field $f(R) = a_R \frac{1}{R^n}$ is independent of R ?

- (A) -2 (B) -1 (C) 1 (D) 2

Ans. (B, D)

Question 52

Consider two coupled circuits, having self-inductances L_1 and L_2 , that carry non-zero currents I_1 and I_2 , respectively. The mutual inductance between the circuits is M with unity coupling coefficient. The stored magnetic energy of the coupled circuits is minimum at which of the following value (s) of $\frac{I_1}{I_2}$?

- (A) $-\frac{M}{L_1}$ (B) $-\frac{M}{L_2}$ (C) $-\frac{L_1}{M}$ (D) $-\frac{L_2}{M}$

Ans. (A, D)

Question 53

Let $(x, y) \in R^2$. The rate of change of the real valued function,

$$V(x, y) = x^2 + x + y^2 + 1$$

at the origin in the direction of the point $(1, 2)$ is _____ (round off to the nearest integer).

Ans. 0.000 to 0.00

Question 54

Consider ordinary differential equations given by

$$\dot{x}_1(t) = 2x_2(t)$$

$$\dot{x}_2(t) = r(t)$$

With initial conditions $x_1(0) = 1$ and $x_2(0) = 0$.

If $r(t) = \begin{cases} 1, & t \geq 0 \\ 0, & t < 0 \end{cases}$, then at $t = 1$, $x_1(t) =$ _____ (round off to the nearest integer).

Ans. 2 to 2

Question 55

Let C be a clockwise oriented closed curve in the complex plane defined by $|z| = 1$. Further, let

$f(z) = jz$ be complex function, where $j = \sqrt{-1}$. Then, $\oint_C f(z) dz =$ _____ (round off to the nearest integer).

Ans. 0 to 0



Question 56

The op-amps in the following circuit are ideal. The voltage gain of the circuit is _____ (round off to the nearest integer).

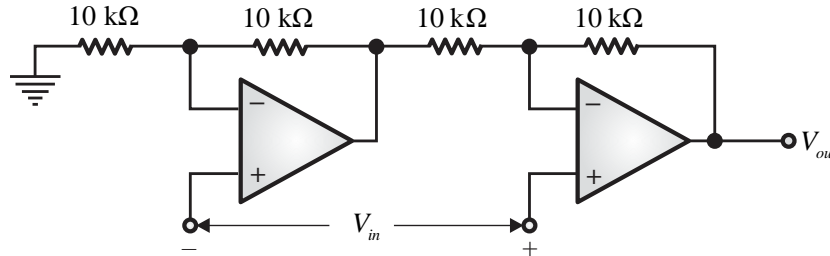

Ans. 2 to 2

Question 57

The switch (S) closes at $t = 0$ sec. The time, in sec, the capacitor takes to charge 50 V is _____ (round off to one decimal place).

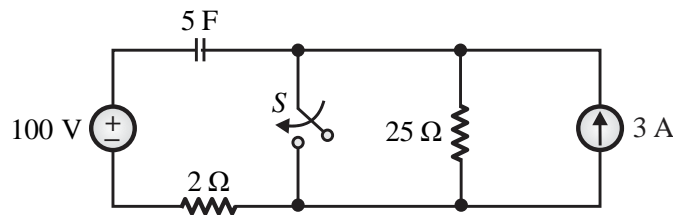

Ans. 4.0 to 4.2

Question 58

In an experiment to measure the active power drawn by a single-phase RL Load connected to an AC source through a $2\ \Omega$ resistor, three voltmeters are connected as shown in the figure below. The voltmeter readings are as follows : $V_{source} = 200\ \text{V}$, $V_R = 9\ \text{V}$, $V_{load} = 199\ \text{V}$. Assuming perfect resistors and ideal voltmeters, the Load-active power measured in this experiment, in W, is _____ (round off to one decimal place).

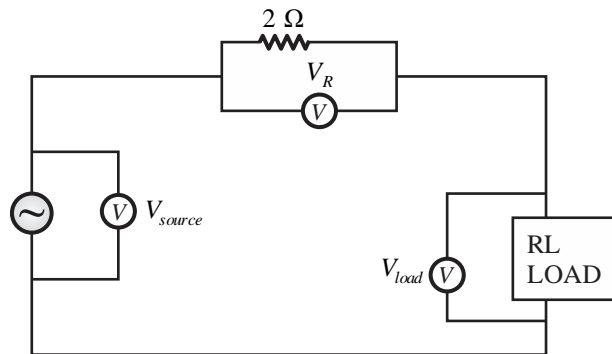

Ans. 77.0 to 80.0

Question 59



In the Wheatstone bridge shown below, the sensitivity of the bridge in terms of change in balancing voltage E for unit change in the resistance R , in mV/Ω , is _____ (round off to two decimal places).

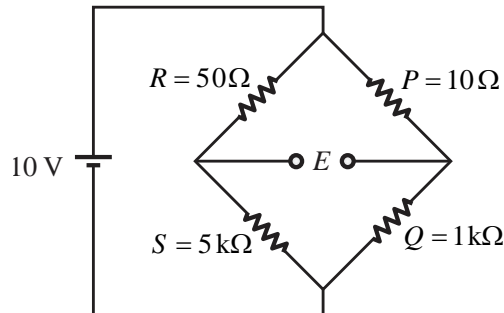

Ans. 1.96 to 2.00

Question 60

The steady state capacitor current of a conventional DC-DC buck converter, working in CCM, is shown in one switching cycle. If the input voltage is 30 V, the value of the inductor used, in mH, is _____ (round off to one decimal place).

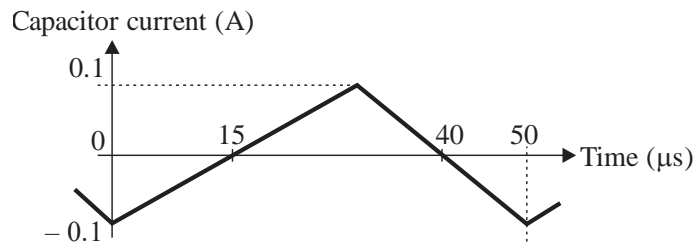

Ans. 1.7 to 1.9

Question 61

An ideal low pass filter has frequency response given by

$$H(j\omega) = \begin{cases} 1, & |\omega| \leq 200\pi \\ 0, & \text{otherwise} \end{cases}$$

Let $h(t)$ be its time domain representation. Then $h(0) =$ _____ (round off to the nearest integer).

Ans. 200 to 200

Question 62

Consider the state-space model

$$\dot{x}(t) = Ax(t) + Br(t), \quad y(t) = Cx(t)$$

Where $x(t), r(t), y(t)$ are the state, input and output, respectively. The matrices A, B, C are given below

$$A = \begin{bmatrix} 0 & 1 \\ -2 & -3 \end{bmatrix}, B = \begin{bmatrix} 0 \\ 1 \end{bmatrix}, C = [1 \quad 0]$$



The sum of the magnitudes of the poles is _____ (round off to nearest integer).

Ans. 3 to 3

Question 63

Using shunt capacitors, the power factor of a 3-phase, 4 kV induction motor (drawing 390 kVA at 0.77 pf lag) is to be corrected to 0.85 pf lag. The line current of the capacitor bank, in A, is _____ (round off to one decimal place).

Ans. 8.5 to 10.0

Question 64

Two units, rated at 100 MW and 150 MW, are enabled for economic load dispatch. When the overall incremental cost is 10,000 Rs./MWh, the units are dispatched to 50 MW and 80 MW respectively. At an overall incremental cost of 10,600 Rs./MWh, the power output of the units are 80 MW and 92 MW, respectively. The total plant MW-output (without overloading any unit) at an overall incremental cost of 11,800 Rs./MWh is _____ (round off to the nearest integer).

Ans. 216 to 216

Question 65

A controller $D(s)$ of the form $(1 + K_D s)$ is to be designed for the plant $G(s) = \frac{1000\sqrt{2}}{s(s+10)^2}$ as shown in the figure. The value of K_D that yields a phase margin of 45° at the gain cross-over frequency of 10 rad/sec is _____ (round off to one decimal place).

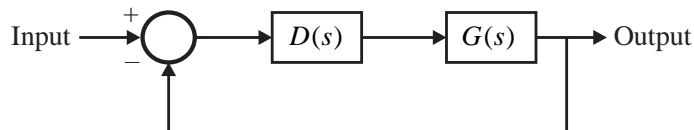

Ans. 0.1 to 0.1

Q.1A to Q.1E Carry one mark each

Question 1 A

In a power system, following a sudden increase in load, the frequency will settle at a lower steady-state value if

- (A) Rotational inertia of the power system reduces.
- (B) A major proportion of the connected load is resistive.
- (C) All generation units for frequency regulation also have voltage regulators enabled.
- (D) The pre-disturbance tie-line power flows are increased.

Question 1 B

A coil of inductance 100 mH and series resistance 100 Ω is connected across a 20 V, 1 kHz supply. The quality factor of the coil at 1 kHz is



- (A) π (B) 2π (C) 10^{-3} (D) 1

Ans. (B)

Question 1 C

A device (single-phase, 50 Hz, AC) yields the following measurements at its terminals : voltage = $141.4\angle -10^\circ$ V , current = $0.7\angle -55^\circ$ A . The power factor of the device is _____ (round off to three decimal places).

Question 1 D

The current, i , in the circuit shown below, in A, is _____ (round off to the nearest integer).

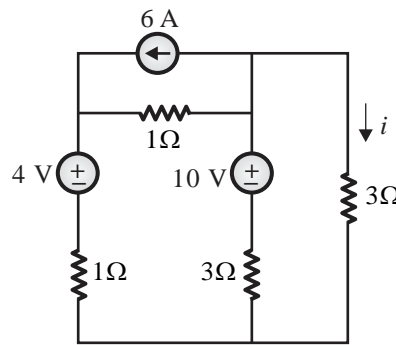

Ans.

Question 1 E

In the circuit, both Q_1 and Q_2 have a current gain of 100 and $V_{BE} = 0.7$ V . The small signal voltage gain is _____ (round off to two decimal places).

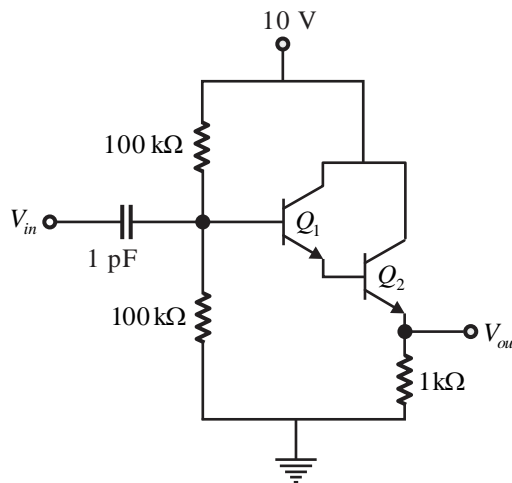

Q.2A to Q.2E Carry one mark each

Question 2 A

The bilateral z-transform of a discrete-time signal $x[n]$ is



$$X(z) = \frac{(1-a^2)}{(z-a)(z^{-1}-a)}$$

With $0 < a < 1$, and the region of convergence $a < |z| < \frac{1}{a}$.

Let $u[n]$ be the discrete-time unit step signal. Then, for $n \geq 0$, the signal $x[n]$ is

- (A) $a^n u[n]$ (B) $\frac{1}{a^n} u[n-1]$
 (C) $a^n (u[n] - u[n-1])$ (D) $-a^n (u[n] - u[n-1])$

Ans.

Question 2 B

Let $G(s) = \frac{1}{(s+1)(s+2)}$. Then the closed-loop system shown in the figure below,

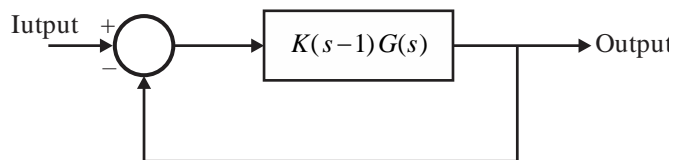

- (A) Stable for all $K > 2$ (B) Unstable for all $K > 2$
 (C) Unstable for all (D) Stable for all $K > 1$

Ans. (B)

Question 2 C

Consider the two statements given below, and select the correct option.

Statement 1 : A directional relay relies on the principle that the CT currents due to fault location on either side of the CT, always differ from each other by a phase of 90° .

Statement 2 : Directional relays are generally deployed in distribution feeders, with their direction towards the source/substation.

- (A) Both the Statements are FALSE.
 (B) Both the Statements are TRUE.
 (C) Statement 1 is FALSE, while Statement 2 is TRUE.
 (D) Statement 1 is TRUE, while Statement 2 is FALSE.

Ans.

Question 2 D

In the Wheatstone bridge shown below, the sensitivity of the bridge in terms of change in balancing voltage E for unit change in the resistance R , in mV/Ω , is _____ (round off to two decimal places).

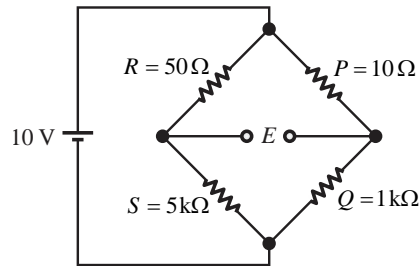

Ans. 1.96 to 2.00

Question 2 E

Given $F = a_x(3y + k_1z) + a_y(k_2x - 2z) + a_z(k_3y - x)$, where a_x, a_y and a_z are the unit vectors in Cartesian coordinate system. The product $k_1k_2k_3$ for which F is irrotational is _____ (rounded off to nearest integer).

