

**General Aptitude****Q.1 to Q.5 Carry One Mark Each****Question 1**

Despite his initial hesitation, Rehman's \_\_\_\_\_ to contribute to the success of the project never wavered. Select the most appropriate option to complete the above sentence.

- (A) Ambivalence (B) Satisfaction  
(C) Resolve (D) revolve

**Ans. C****Question 2**

Bird : Nest :: Bee : \_\_\_\_\_

Select the correct option to complete the analogy.

- (A) Kennel (B) Hammock (C) Hive (D) Lair

**Ans. (C)****Question 3**

If  $Pe^x = Qe^{-x}$  for all real values of  $x$ , which one of the following statements is true?

- (A)  $P = Q = 0$  (B)  $P = Q = 1$   
(C)  $P = 1; Q = -1$  (D)  $\frac{P}{Q} = 0$

**Ans. (A)****Question 4**

The paper as shown in the figure is folded to make a cube where each square corresponds to a particular face of the cube. Which one of the following options correctly represents the cube?

Note: The figures shown are representative.

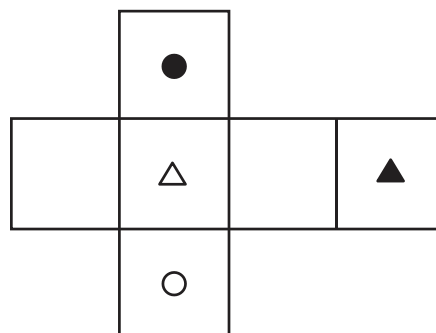

(A)

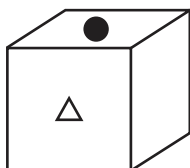

(C)

(B)



(D)

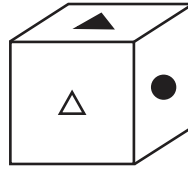
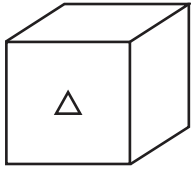

Ans. (A)

**Question 5**

Let  $p_1$  and  $p_2$  denote two arbitrary prime numbers. Which one of the following statements is correct for all values of  $p_1$  and  $p_2$  ?

- (A)  $p_1 + p_2$  is not a prime number. (B)  $p_1 p_2$  is not a prime number.  
(C)  $p_1 + p_2 + 1$  is a prime number. (D)  $p_1 p_2 + 1$  is a prime number.

Ans. (B)

**Q.6 to Q.10 Carry Two Marks Each****Question 6**

Based only on the conversation below, identify the logically correct inference:

"Even if I had known that you were in the hospital, I would not have gone there to see you", Ramya told Josephine.

- (A) Ramya knew that Josephine was in the hospital.  
(B) Ramya did not know that Josephine was in the hospital.  
(C) Ramya and Josephine were once close friends; but now, they are not.  
(D) Josephine was in the hospital due to an injury to her leg.

Ans. B

**Question 7**

If IMAGE and FIELD are coded as FHBNJ and EMFJG respectively then, which one among the given options is the most appropriate code for BEACH ?

- (A) CEADP (B) IDBFC (C) JGIBC (D) IBCEC

Ans. B

**Question 8**

Which one of the following options is correct for the given data in the table

Iteration ( $i$ )	0	1	2	3
Input ( $I$ )	20	-4	10	15
Output ( $X$ )	20	16	26	41
Output ( $Y$ )	20	-80	-800	-12000

- (A)  $X(i) = X(i-1) + I(i)$ ;  $Y(i) = Y(i-1)$ ;  $i > 0$   
(B)  $X(i) = X(i-1)I(i)$ ;  $Y(i) = Y(i-1) + I(i)$ ;  $i > 0$   
(C)  $X(i) = X(i-1)I(i)$ ;  $Y(i) = Y(i-1)I(i-1)$ ;  $i > 0$   
(D)  $X(i) = X(i-1) + I(i)$ ;  $Y(i) = Y(i-1)I(i-1)$ ;  $i > 0$

Ans. A

## Question 9

In the given figure, PQRS is a square of side 2 cm and PLMN is a rectangle. The corner L of the rectangle is on the side QR. Side MN of the rectangle passes through the corner S of the square.

What is the area (in  $\text{cm}^2$ ) of the rectangle PLMN?

Note: The figure shown is representative.

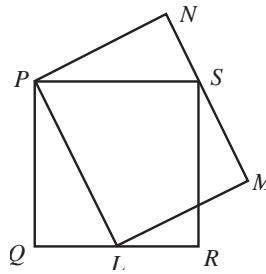
(A)  $2\sqrt{2}$ 

(B) 2

(C) 8

(D) 4

Ans. (D)

## Question 10

The diagram below shows a river system consisting of 7 segments, marked P, Q, R, S, T, U, and V. It splits the land into 5 zones, marked Z1, Z2, Z3, Z4, and Z5. We need to connect these zones using the least number of bridges. Out of the following options, which one is correct?

Note: The figure shown is representative.

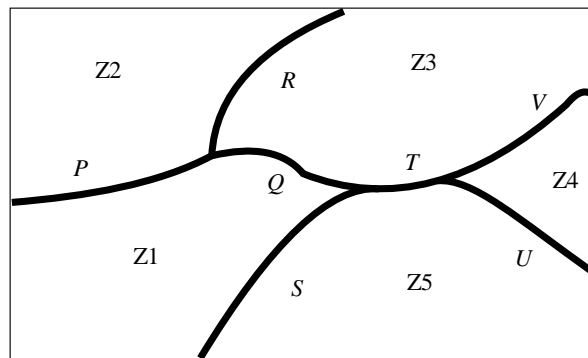

(A) Bridges on P, Q, and T

(B) Bridges on P, Q, S, and T

(C) Bridges on Q, R, T, and V

(D) Bridges on P, Q, S, U, and V

Ans. C

**Technical Section**

### Q.11 to Q.35 Carry One Mark Each

## Question 11

A  $2n \times 2n$  matrix  $A = [a_{ij}]$  has its elements as

$$a_{ij} = \begin{cases} \beta & \text{if } (i + j) \text{ is odd} \\ -\beta & \text{if } (i + j) \text{ is even} \end{cases}$$

where  $n$  is any integer greater than 2 and  $\beta$  is any non-zero real number. The rank of  $A$  is

- (A) 1
- (B) 2
- (C)  $n$
- (D)  $2n$

**Ans. (A)**

**Question 12**

The solution of the differential equation  $\frac{dy}{dx} = 9\frac{x}{y}$  represents

- (A) a hyperbola
- (B) a parabola
- (C) an ellipse
- (D) a circle

**Ans. (A)**

**Question 13**

The working of the hand-held metal detector most widely used by security personnel for human frisking is based on the principle of

- (A) change in reluctance of an iron core in presence of a metallic object
- (B) change in conductance of an iron core in presence of a metallic object
- (C) electric field induced by a metallic object
- (D) eddy current generation in a metallic object

**Ans. (D)**

**Question 14**

The primary coil of a linear variable differential transformer (LVDT) is supplied with AC voltage as shown in the figure. The secondary coils are connected in series opposition and the output is measured using a true RMS voltmeter. The displacement  $x$  of the core is indicated in mm on a linear scale. At the null position  $x = 0$ , the voltmeter reads 0 V. If the voltmeter reads 0.2 V for a displacement of  $= +2$  mm, then for a displacement of  $x = -3$  mm, the voltmeter reading, in V, is

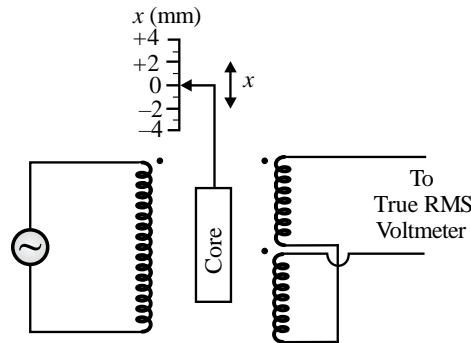

- (A) - 0.3
- (B) - 0.1
- (C) 0.3
- (D) 0.5

Ans. (C)

**Question 15**

In the force transducer shown in Figure (a), four identical strain gauges S1, S2, S3, and S4 are mounted on a cantilever at equal distance from its base. S1 and S2 are mounted on the top surface and S3 and S4 are mounted on the bottom surface, as shown in the Figure (a). These strain gauges are to be connected to form a Wheatstone bridge consisting of four arms A, B, C, and D, as shown in the Figure (b). From the following options, the correct order to maximize the measurement sensitivity is

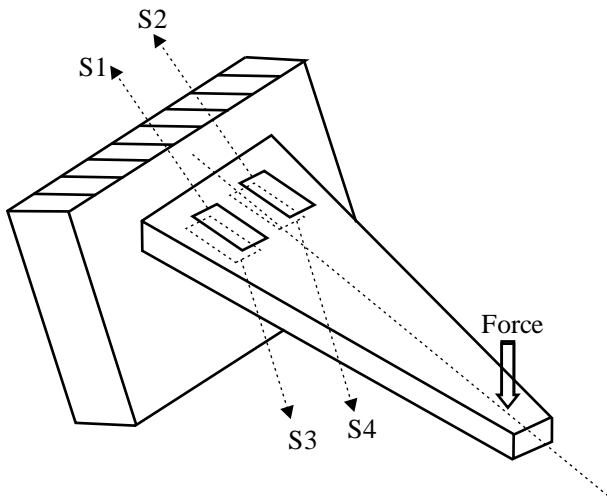

Figure (a)

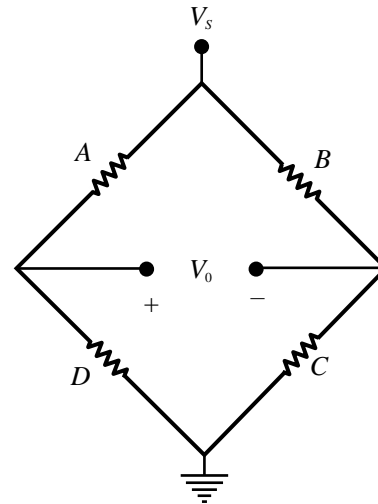

Figure (b)

- (A) A → S1, B → S2, C → S4, D → S3
- (B) A → S1, B → S4, C → S3, D → S2
- (C) A → S1, B → S2, C → S3, D → S4
- (D) A → S1, B → S4, C → S2, D → S3

Ans. (D)

**Question 16**

Let a continuous-time signal be  $x(t) = e^{j9t} + e^{j5t}$ , where  $j = \sqrt{-1}$  and  $t$  is in seconds. The fundamental period of magnitude of  $x(t)$ , in seconds, is

- (A)  $\pi$   
 (B)  $\frac{\pi}{2}$   
 (C)  $\frac{\pi}{5}$   
 (D)  $\frac{\pi}{9}$

Ans. (B)

**Question 17**

The minimized expression of the Boolean function  $Y(P, Q, R)$  implemented by the multiplexer (MUX) circuit shown in the figure is

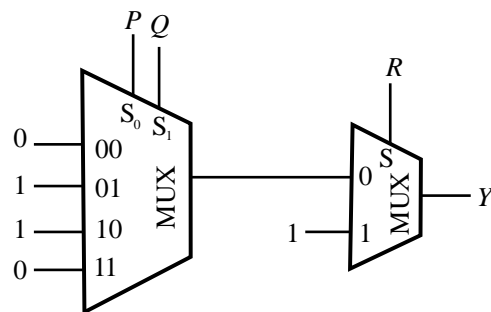

- (A)  $Y = R + (P \oplus Q)$   
 (B)  $Y = R(P \oplus Q)$   
 (C)  $Y = R + \overline{(P \oplus Q)}$   
 (D)  $Y = R \oplus (P \oplus Q)$

Ans. (A)

**Question 18**

The 4-bit signed 2's complement form of  $(5)_{10} + (5)_{10}$  is

- (A)  $(-6)_{10}$   
 (B)  $(-7)_{10}$   
 (C)  $(-5)_{10}$   
 (D)  $(-8)_{10}$

Ans. (A)

**Question 19**

An infinite sheet of uniform charge  $\rho_s = 10\text{C/m}^2$  is placed on  $z = 0$  plane. The medium surrounding the sheet has a relative permittivity of 10. The electric flux density, in  $\text{C/m}^2$ , at a point  $P(0,0,5)$ , is

Note :  $\hat{a}$ ,  $\hat{b}$ , and  $\hat{c}$  are unit vectors along the  $x$ ,  $y$ , and  $z$  directions, respectively.

- (A)  $5 \hat{c}$   
 (B)  $0.25 \hat{c}$

- (C)  $10 \hat{c}$
- (D)  $0.5 \hat{c}$

Ans. (A)

**Question 20**

For the ideal op-amp based circuit shown in the figure, the ratio  $\frac{V}{I}$  is

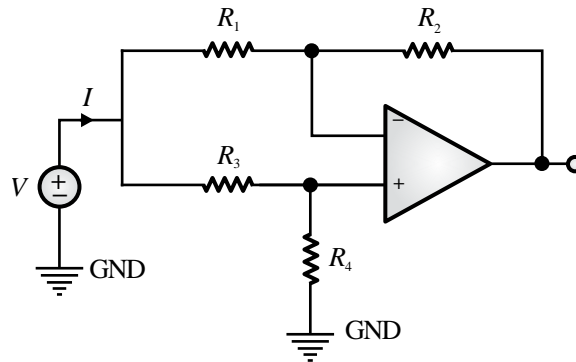

- (A)  $\left(\frac{R_3+R_4}{R_1+R_3}\right) R_1$
- (B)  $\left(\frac{R_2+R_4}{R_1+R_3}\right) R_3$
- (C)  $R_1 + R_3$
- (D)  $R_3 + R_4$

Ans. (A)

**Question 21**

In a single-phase AC circuit, the power consumed by load resistance  $R_L$  for an excitation  $V_S$  is measured using a wattmeter. The same wattmeter is connected in two different topologies, Topology-A and Topology-B, as shown in the figure. Different branch currents and voltage drops are also marked in the figure. Among the following options, the condition that ensures low error in the wattmeter reading for both the topologies is

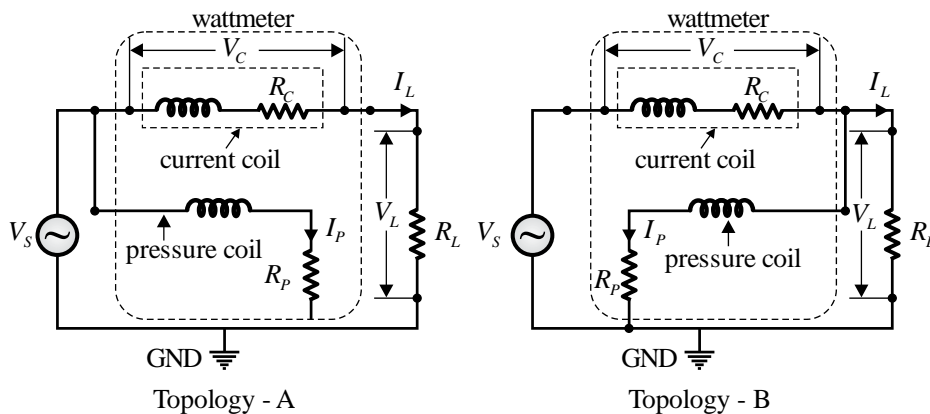

- (A)  $V_L \gg V_C$  for Topology-A and  $I_L \gg I_P$  for Topology-B
- (B)  $V_L \gg V_C$  for Topology-A and  $I_L \ll I_P$  for Topology-B
- (C)  $V_L \ll V_C$  for Topology-A and  $I_L \ll I_P$  for Topology-B

(D)  $V_L \ll V_C$  for Topology-A and  $I_L \gg I_p$  for Topology-B

Ans. (A)

**Question 22 Sensor & Industrial Instrumentation, Temperature Measurement**

Match the following sensors with their most suitable applications.

	Sensor		Application
P	Rotary Variable Differential Transformer	I.	Vacuum measurement
Q	Thermocouple	II.	Force measurement
R	Ionization Gauge	III.	Angular displacement measurement
S	Strain Gauge	IV.	Temperature measurement

- (A) P-II, Q-III, R-I, S-IV
- (B) P-II, Q-IV, R-III, S-I
- (C) P-III, Q-IV, R-II, S-I
- (D) P-III, Q-IV, R-I, S-II

Ans. (D)

**Question 23**

A  $3\frac{1}{2}$  digit digital voltmeter has a specified accuracy of  $\pm(0.5\% + 1)$ . If it is used to measure 10 V DC voltage, the error in the measurement would be

Note: Accuracy of the digital voltmeter is expressed as  $\pm (\% \text{ of reading} + \text{digit})$ .

- (A)  $\pm 0.4\%$
- (B)  $\pm 1.5\%$
- (C)  $\pm 0.6\%$
- (D)  $\pm 1\%$

Ans. (C)

**Question 24**

The circuit shown in Figure (a) can be represented using its equivalent T-model as shown in Figure (b). The values of the inductances  $L_1, L_2$ , and  $L_3$  in the equivalent T-model are

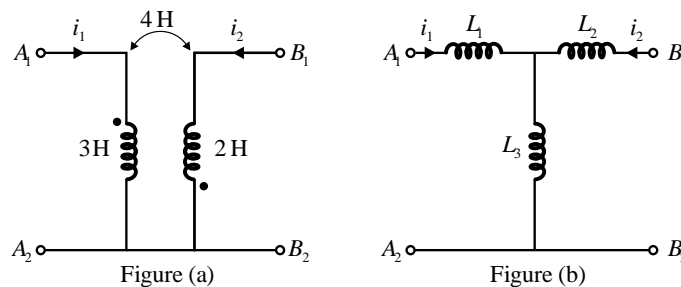

- (A)  $L_1 = 7H, L_2 = 6H, L_3 = -4H$
- (B)  $L_1 = -1H, L_2 = -2H, L_3 = 4H$
- (C)  $L_1 = 3H, L_2 = 2H, L_3 = 9H$

(D)  $L_1 = 1\text{H}, L_2 = -2\text{H}, L_3 = -4\text{H}$

Ans. (A)

**Question 25**

Three parallel admittances  $Y_a = -j0.2\text{ S}$ ,  $Y_b = 0.3\text{ S}$ , and  $Y_c = j0.4\text{ S}$  connected in parallel with a voltage source  $V_s = 10\angle 45^\circ\text{V}$ , draw a total current  $I_s$  from the source. The currents flowing through each of these admittances are  $I_a, I_b$ , and  $I_c$ , respectively. Let  $I = I_b + I_c$ . The phase relation between  $I$  and  $I_s$  is

- (A)  $I$  leads  $I_s$  by  $19.44^\circ$
- (B)  $I$  lags  $I_s$  by  $19.44^\circ$
- (C)  $I$  leads  $I_s$  by  $33.69^\circ$
- (D)  $I$  lags  $I_s$  by  $33.69^\circ$

Ans. (A)

**Question 26**

An oscilloscope has an input resistance of  $1\text{M}\Omega$ . A 10X passive attenuating probe is connected to it to increase the input voltage range as well as the effective input resistance. The effective input resistance, in  $\text{M}\Omega$ , seen into the probe tip is

- (A) 0.9
- (B) 9.1
- (C) 10
- (D) 11

Ans. (C)

**Question 27**

For the transfer function  $(s) = 1 + \frac{2s-1}{s^3+5s^2+3s+22}$ , the number of zeros lying in the left half of the  $s$ -plane is

- (A) 0
- (B) 1
- (C) 2
- (D) 3

Ans. (D)

**Question 28**

Consider the control system block diagram given in Figure (a). The loop transfer function  $G(s)H(s)$  does not have any pole on the  $j\omega$ -axis. The counterclockwise contour with infinite radius, as shown in Figure (b), encircles two poles of  $G(s)H(s)$ . Choose the correct statement from the following options for closed loop stability of the system.

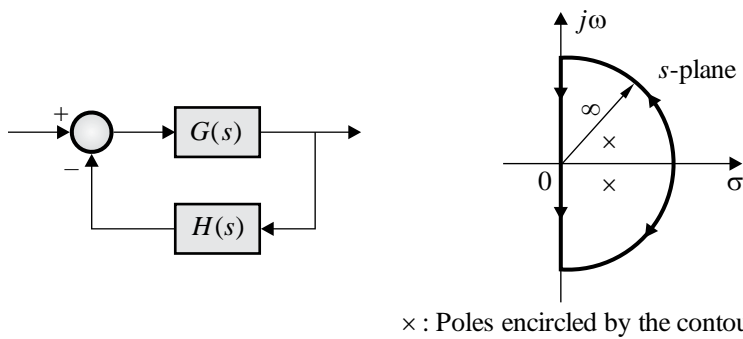

Figure (a)

Figure (b)

x : Poles encircled by the contour

- (A) The locus of  $G(s)H(s)$  should encircle the origin twice in the counterclockwise direction
- (B) The locus of  $1 + G(s)H(s)$  should encircle the origin twice in the clockwise direction
- (C) The locus of  $G(s)H(s)$  should encircle the  $-1 + j0$  point twice in the counterclockwise direction
- (D) The locus of  $1 + G(s)H(s)$  should encircle the  $-1 + j0$  point twice in the clockwise direction

Ans. (B)

**Question 29**

A Boolean function  $X$  is given as  $X = \bar{A}\bar{B} + \bar{A}\bar{C}$ . The reduced form of  $\bar{X}$  is

- (A)  $\bar{A} + \bar{B} + \bar{C}$
- (B)  $A + BC$
- (C)  $\bar{A} + \bar{B} + C$
- (D)  $B + AC$

Ans. (B)

**Question 30**

A 60 V DC source with an internal resistance  $R_{int} = 0.5\Omega$  is connected through a switch to a pair of infinitely long rails separated by  $l = 1$  m as shown in the figure. The rails are placed in a constant, uniform magnetic field of flux density = 0.5 T, directed into the page. A conducting bar placed on these rails is free to move. At the instant of closing the switch, the force induced on the bar is

Note: Assume there is no friction between the bar and the rails. The resistances of the conducting bar and the rails are zero.

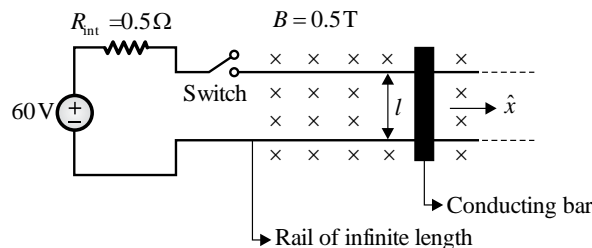

- (A) 60 N in the direction of  $\hat{x}$
- (B) 60 N opposite to the direction of  $\hat{x}$
- (C) 120 N in the direction of  $\hat{x}$
- (D) 120 N opposite to the direction of  $\hat{x}$

Ans. (A)

**Question 31**

The circuits mentioned in the following options are realized using ideal opamp. Among these, the circuit(s) performing non-linear operation on the input signal is/are

- (A) Instrumentation amplifier
- (B) Schmitt trigger
- (C) Logarithmic amplifier
- (D) Precision rectifier

Ans. (B,C,D)

**Question 32**

If one of the eigenvectors of the matrix  $A = \begin{bmatrix} -1 & -1 \\ x & -4 \end{bmatrix}$  is along the direction of  $\begin{bmatrix} \alpha \\ 2\alpha \end{bmatrix}$ , where  $\alpha$  is any non-zero real number, then the value of  $x$  is \_\_\_\_\_ (in integer).

Ans. 2 to 2

**Question 33**

Consider the function  $f(z) = \frac{2z+1}{z^2-z}$ , where  $z$  is a complex variable. The sum of the residues at singular points of  $f(z)$  is \_\_\_\_\_ (in integer).

Ans. 2 to 2

**Question 34**

A dual-slope ADC has a fixed integration time of 100 ms. The reference voltage of the ADC is  $-5$  V. The time taken by the ADC to measure an input voltage of 1.25 V is \_\_\_\_\_ ms (rounded off to the nearest integer).

Ans. 125 to 125

**Question 35**

In the circuit shown, assume that the BJT in the circuit has very high  $\beta$  and  $V_{BE} = 0.7$  V, and the Zener diode has  $V_Z = 4.7$  V. The current  $I$  through the LED is \_\_\_\_\_ mA (rounded off to two decimal places).

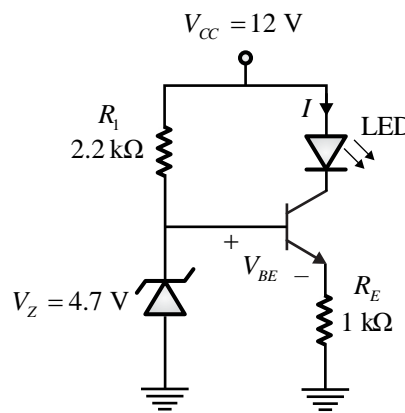

Ans. 3.90 to 4.10

## Q.36 to Q.65 Carry Two Marks Each

**Question 36**

The value of the surface integral  $\iint_S (2x + z)dy dz + (2x + z)dx dz + (2z + y)dx dy$  over the sphere  $S: x^2 + y^2 + z^2 = 9$  is

- (A)  $72\pi$
- (B)  $144\pi$
- (C)  $36\pi$
- (D)  $432\pi$

**Ans. (B)****Question 37**

Newton-Raphson method is used to compute the inverse of the number 1.6. Among the following options, the initial guess of the solution that results in non-convergence of the iterative process is

- (A) 0.55
- (B) 0.75
- (C) 1.15
- (D) 1.25

**Ans. (D)****Question 38**

The value of the integral  $\int_{-\pi}^{\pi} (\cos^6 x + \cos^4 x)dx$  is

- (A)  $\frac{\pi}{2}$
- (B)  $\frac{5\pi}{8}$
- (C)  $\frac{11\pi}{8}$
- (D)  $\frac{9\pi}{8}$

**Ans. (C)****Question 39**

Let  $y[n] = \frac{1}{\alpha}y[n-1] + x[n]$ , where  $\alpha > 1$  and real, represent a difference equation of a causal discrete-time linear time invariant system. The system is initially at rest.

If  $x[n] = \delta[n-p]$  where  $p > 10$ , the value of  $y[p+1]$  is

- (A) 0
- (B) 1
- (C)  $\frac{1}{\alpha}$
- (D)  $\frac{1}{\alpha^2}$

**Ans. (C)**

**Question 40**

The clock frequency of the digital circuit shown in the figure is 12 MHz. The frequencies of the output (F) corresponding to Control = 0 and Control = 1, respectively, are

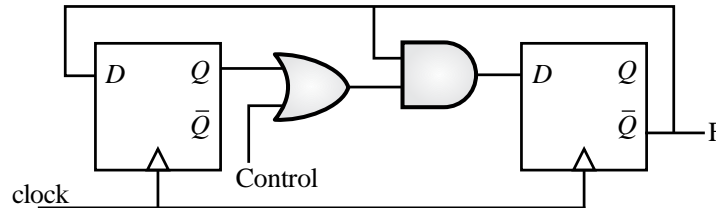

- (A) 4 MHz and 6 MHz
- (B) 6 MHz and 4 MHz
- (C) 3 MHz and 4 MHz
- (D) 3 MHz and 6 MHz

Ans. (A)

**Question 41**

A chopper amplifier shown in the figure is designed to process a biomedical signal  $v_{in}(t)$  to generate conditioned output  $v_{out}(t)$ . The signals  $v_{in}(t)$  and  $v_{os}(t)$  are band limited to 50 Hz and 10 Hz, respectively. For the system to operate as a linear amplifier, choose the correct statement from the following options.

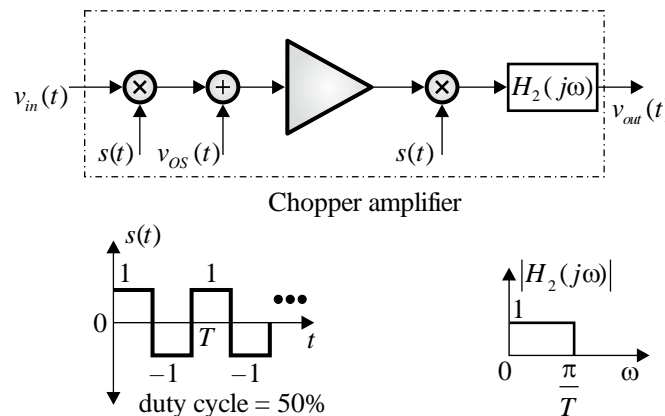

- (A) The minimum frequency of  $s(t)$  required is 100 Hz and  $v_{os}(t)$  gets attenuated by the system
- (B) The minimum frequency of  $s(t)$  required is 100 Hz and  $v_{os}(t)$  also gets amplified by the system by a factor  $\frac{200}{\pi}$
- (C) The minimum frequency of  $s(t)$  required is 80 Hz and  $v_{os}(t)$  gets attenuated by the system
- (D) The minimum frequency of  $s(t)$  required is 80 Hz and  $v_{os}(t)$  also gets amplified by the system by a factor  $\frac{200}{\pi}$

Ans. (A)

**Question 42**

An 8-bit microprocessor has 16-bit address bus ( $A_{15} - A_0$ ) where  $A_0$  is the LSB. As shown in Figure (a), it has a pre-installed 4 KB ROM whose starting address is 0000 H. The processor needs to be

upgraded by adding a 16 KB RAM as shown in Figure (b). The address range for the newly added RAM is

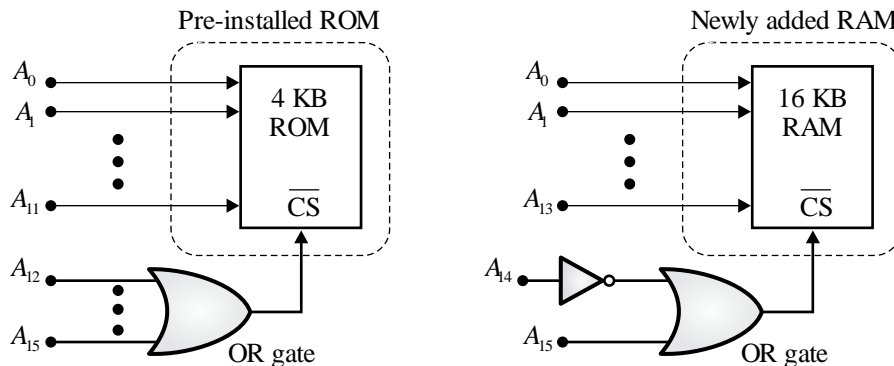

Figure (a)

Figure (b)

- (A) 1000 H - 4FFF H
- (B) 3000 H - 6FFF H
- (C) 4000 H - 7FFF H
- (D) 8000 H - BFFF H

Ans. (C)

**Question 43**

A 3-bit DAC is implemented using ideal opamp and switches as shown in the figure. Each of the switches gets closed when its corresponding digital input is at logic 1. For a digital input of 110, the resistance  $R_{in}$  seen from the reference source and the current  $I$ , are

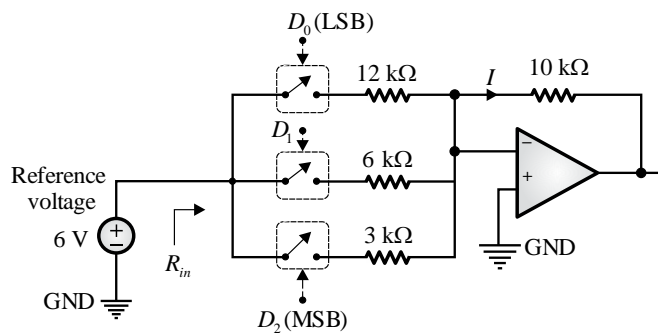

- (A)  $R_{in} = 2 \text{ k}\Omega$  and  $I = 3 \text{ mA}$
- (B)  $R_{in} = 12 \text{ k}\Omega$  and  $I = 0.5 \text{ mA}$
- (C)  $R_{in} = \infty \Omega$  and  $I = 1 \text{ mA}$
- (D)  $R_{in} = \infty \Omega$  and  $I = 3 \text{ mA}$

Ans. (A)

**Question 44**

Power consumed by a three-phase balanced load is measured using two-wattmeter method. The per-phase average power drawn by the load is 30 kW at  $\frac{\sqrt{3}}{2}$  lagging power factor. The readings of the wattmeters will be

- (A) 15 kW and 15 kW
- (B) 22.5 kW and 7.5 kW
- (C) 60 kW and 30 kW
- (D) 45 kW and 45 kW

Ans. (C)

#### Question 45

The bridge circuit, shown in Figure (a), can be equivalently represented using the circuit shown in Figure (b). The values of  $R_1$ ,  $R_2$ , and  $V_C$  in the equivalent circuit are

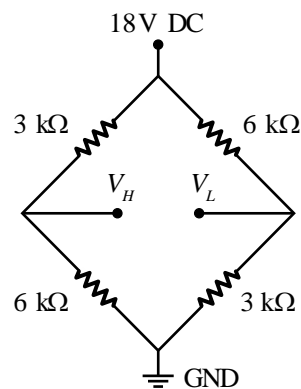

Figure (a)

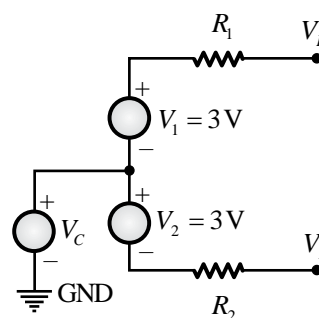

Figure (b)

- (A)  $R_1 = 6\text{k}\Omega$ ,  $R_2 = 3\text{k}\Omega$ , and  $V_C = 9\text{ V}$
- (B)  $R_1 = 3\text{k}\Omega$ ,  $R_2 = 6\text{k}\Omega$ , and  $V_C = 4.5\text{ V}$
- (C)  $R_1 = 2\text{k}\Omega$ ,  $R_2 = 2\text{k}\Omega$ , and  $V_C = 9\text{ V}$
- (D)  $R_1 = 2\text{k}\Omega$ ,  $R_2 = 2\text{k}\Omega$ , and  $V_C = 4.5\text{ V}$

Ans. (C)

#### Question 46

A 2-pole, 50 Hz, 3-phase induction motor supplies power to a certain load at 2970 rpm. The torque-speed curve of this machine follows a linear relationship between synchronous speed and 95 % of synchronous speed. Assume mechanical and stray losses to be zero. If the load torque of the motor is doubled, the new operating speed of the motor, in rpm, is

- (A) 2940
- (B) 2812
- (C) 2970
- (D) 2850

Ans. (A)

#### Question 47

The figure shows a closed-loop system with a plant  $G(s) = \frac{1}{s^2}$  and a lead compensator  $C(s)$ . The compensator is designed to place the dominant closed-loop poles at  $-1.5 \pm j\frac{\sqrt{27}}{2}$ . From the following options, choose the phase lead that the compensator needs to contribute.

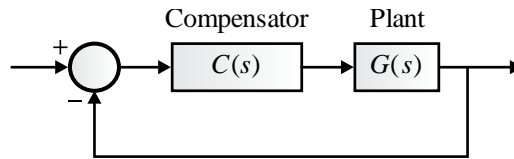

- (A)  $30^\circ$
- (B)  $60^\circ$
- (C)  $90^\circ$
- (D)  $120^\circ$

**Ans. (B)**

**Question 48**

Let  $f(t)$  and  $g(t)$  represent continuous-time real-valued signals. If  $h(t)$  denotes cross-correlation between  $f(t)$  and  $g(-t)$ , its continuous-time Fourier transform  $H(j\omega)$  equals

Note:  $F(j\omega)$  and  $G(j\omega)$  denote the continuous-time Fourier transforms of  $f(t)$  and  $g(t)$ , respectively.

- (A)  $F(j\omega)G(j\omega)$
- (B)  $F(-j\omega)G(j\omega)$
- (C)  $F(j\omega)G(-j\omega)$
- (D)  $-F(j\omega)G(-j\omega)$

**Ans. (C)**

**Question 49**

Choose the correct statement(s) from the following options, regarding Cauchy's theorem on complex integration  $\oint_C f(z) dz$  where  $C$  is a simple closed path in a simply connected domain  $D$ .

- (A) Cauchy's theorem cannot be directly applied to conclude that  $\oint_C f(z) dz = 0$  when  $f(z) = \frac{1}{z^2}$ , and  $C$  is the unit circle
- (B) If  $f(z)$  is analytic in  $D$ , then it can be concluded that  $\oint_C f(z) dz = 0$  for any simple closed path  $C$  in  $D$
- (C) The function  $f(z)$  must be analytic in  $D$  to conclude  $\oint_C f(z) dz = 0$  for any simple closed path  $C$  in  $D$
- (D)  $\oint_C f(z) dz \neq 0$  when  $f(z) = \frac{1}{z^2}$ , since the function is not analytic at  $z = 0$

**Ans. (A,B)**

**Question 50**

The plant in the feedback control system shown in the figure is  $P(s) = \frac{a}{s^2 - b^2}$   $a > 0$  and  $b > 0$ . The type(s) of controller  $C(s)$  that CANNOT stabilize the plant is/are

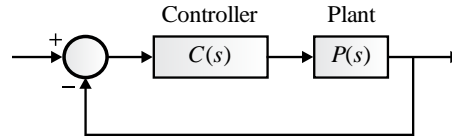

- (A) proportional (P) controller
- (B) integral (I) controller
- (C) proportional-integral (PI) controller
- (D) proportional-derivative (PD) controller

**Ans. (A,B,C)****Question 51**

Choose the eigen function(s) of stable linear time-invariant continuous-time systems from the following options.

- (A)  $e^{j\frac{2\pi}{3}t}$
- (B)  $\cos\left(\frac{2\pi}{3}t\right)$
- (C)  $2^t$
- (D)  $\sin\left(\frac{2\pi}{3}t\right)$

**Ans. (A,C)****Question 52**

The probability of a student missing a class is 0.1. In a total number of 10 classes, the probability that the student will not miss more than one class is \_\_\_\_\_(rounded off to two decimal places).

**Ans. 0.72 to 0.76****Question 53**

A metallic strain-gauge (SG) with resistance  $R_{SG}$  is connected as shown in the figure, where  $R_{L1}, R_{L2}, R_{L3}$  represent the lead wire resistances. The SG has a gauge factor of 2 and nominal resistance  $R_N$  of 125  $\Omega$ . When the SG is subjected to a tensile strain of  $2 \times 10^{-3}$ , the resulting change in  $R_{SG}$  is  $\Delta R$ . The  $\Delta R$  value is measured as  $\Delta R_{MEAS} = R_{EQ2} - R_{EQ1}$ . The  $R_{EQ1}$  and  $R_{EQ2}$  are the equivalent resistances measured between the terminals 1 and 2, and terminals 2 and 3, respectively.

If  $R_{L1} = R_{L2} = 5 \Omega$ , and  $R_{L3} = 4.95 \Omega$ , the measured value of tensile strain is \_\_\_\_\_  $\times 10^{-3}$  (rounded off to two decimal places).

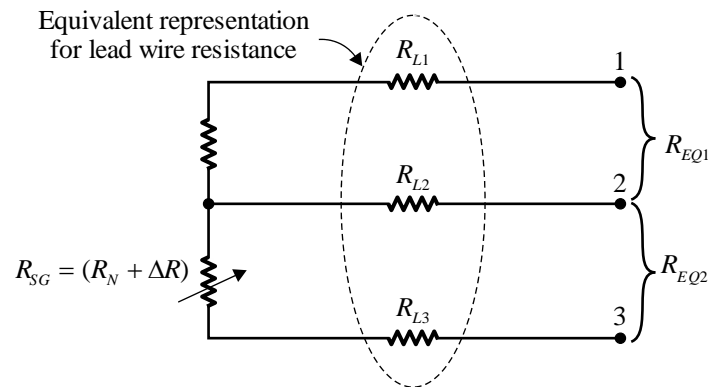

Ans. 1.75 to 1.85

Question 54

Let  $X(e^{j\omega})$  represent the discrete time Fourier transform of a 4-length sequence  $x[n]$ , where  $x[0] = 1, x[1] = 2, x[2] = 2$ , and  $x[3] = 4$ .  $X(e^{j\omega})$  is sampled at  $\omega_k = \frac{2\pi k}{3}$  to generate a periodic sequence in  $k$  with period 3, where  $k$  represents an integer. Let  $y[n]$  represent another sequence such that its discrete Fourier transform  $Y[k]$  is given as  $Y[k] = X(e^{j\omega_k})$  for  $0 \leq k \leq 2$ . The value of  $y[0]$  is \_\_\_\_\_ (in integer).

Ans. 5 to 5

Question 55

A schematic of a Michelson interferometer, used for the measurement of refractive index of gas, is shown in the figure. The transparent chamber is filled with a gas of refractive index  $n_g$ , where  $n_g \neq 1$ , at atmospheric pressure. If a 532 nm laser beam produces 30 interference fringes on the screen, then the number of fringes produced by a 632.8 nm laser beam will be \_\_\_\_\_ (rounded off to one decimal place).

Note: Assume that the effect of beamsplitter width is negligible. The setup is placed in air medium with refractive index equal to 1.

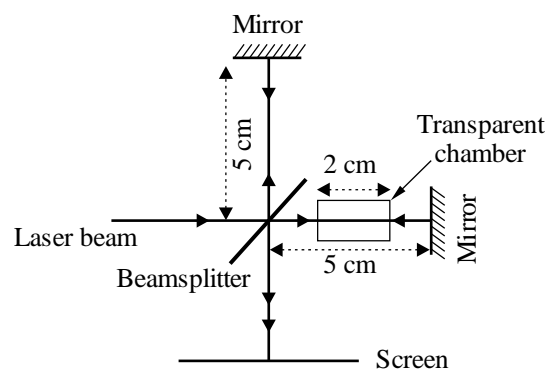

Ans. 24.5 to 25.5

Question 56

Consider an AC bridge shown in the figure with  $R = 300\Omega, R_1 = 1000\Omega, R_2 = 500\Omega, L = 30\text{mH}$ , and a detector  $D$ . At the bridge balance condition, the frequency of the excitation source  $V_S$  is \_\_\_\_\_ kHz (rounded off to two decimal places).

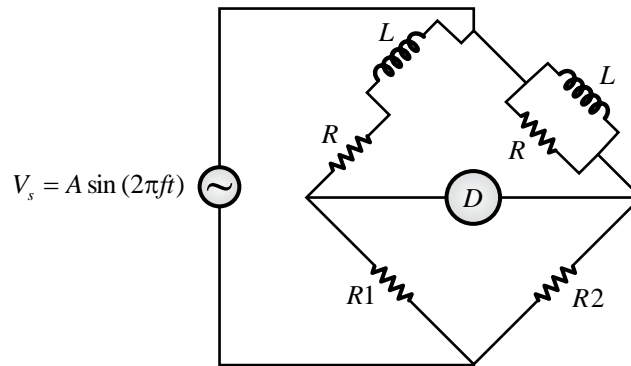

Ans. 1.55 to 1.65

**Question 57**

An air filled parallel plate electrostatic actuator is shown in the figure. The area of each capacitor plate is  $100 \mu\text{m} \times 100 \mu\text{m}$ . The distance between the plates  $d_0 = 1 \mu\text{m}$  when both the capacitor charge and spring restoring force are zero as shown in Figure (a). A linear spring of constant  $k = 0.01 \text{ N/m}$  is connected to the movable plate. When charge is supplied to the capacitor using a current source, the top plate moves as shown in Figure (b). The magnitude of minimum charge ( $Q$ ) required to momentarily close the gap between the plates is  $\text{_____} \times 10^{-14} \text{ C}$  (rounded off to two decimal places).

Note: Assume a full range of motion is possible for the top plate and there is no fringe capacitance. The permittivity of free space is  $\epsilon_0 = 8.85 \times 10^{-12} \text{ F/m}$  and relative permittivity of air ( $\epsilon_r$ ) is 1.

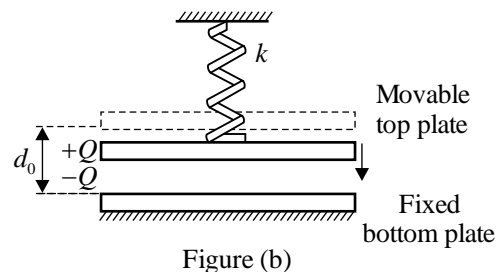
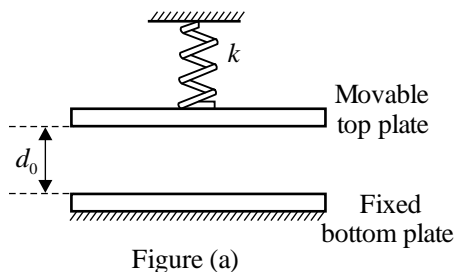

Ans. 4.00 to 4.40

**Question 58**

The resistance of a thermistor is measured to be  $2.25 \text{ k}\Omega$  at  $30^\circ\text{C}$  and  $1.17 \text{ k}\Omega$  at  $60^\circ\text{C}$ . Its material constant  $\beta$  is  $\text{_____ K}$  (rounded off to two decimal places).

Ans. 2160 to 2210

**Question 59**

A feedback control system is shown in the figure.

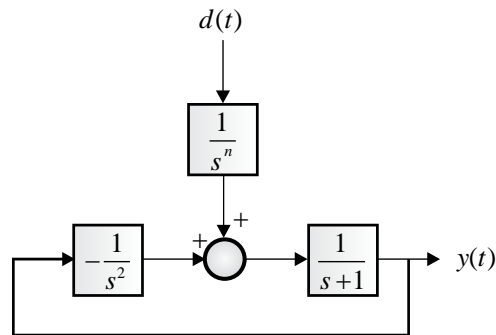

The maximum allowable value of  $n$  such that the output  $y(t)$ , due to any step disturbance signal  $d(t)$ , becomes zero at steady-state, is \_\_\_\_\_ (in integer).

Ans. 1 to 1

Question 60

The circuit given in the figure is driven by a voltage source  $V_s = 25\sqrt{2}\angle 30^\circ\text{V}$ . The system is operating at a frequency of 50 Hz. The transformers are assumed to be ideal. The average power dissipated, in W, in the 50 kΩ resistance is \_\_\_\_\_ (rounded off to two decimal places).

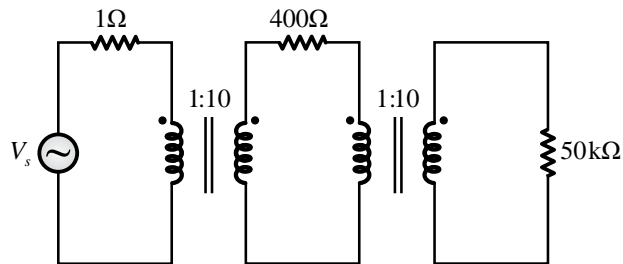

Ans. 31.00 to 31.50

Question 61

In the circuit shown, the galvanometer (G) has an internal resistance of 100 Ω. The galvanometer current  $I_G$  is \_\_\_\_\_  $\mu\text{A}$  (rounded off to the nearest integer).

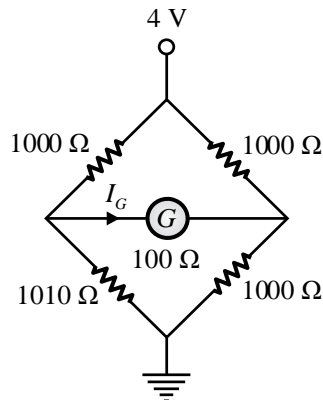

Ans. 9 to 9

Question 62

A series RLC circuit resonates at  $7500 \text{ rad/s}$  for inductance  $L = 20 \text{ mH}$  and resistance  $R = 10 \Omega$ . The uncertainties in the measurement of  $L$  and  $R$  are  $0.8 \text{ mH}$  and  $0.3 \Omega$ , respectively. The percentage uncertainty in the measurement of quality factor is \_\_\_\_\_ % (rounded off to one decimal place).

Ans. 4.5 to 5.5

Question 63

In the circuit shown, the switch is opened at  $t = 0 \text{ s}$ . The current  $i(t)$  at  $t = 2 \text{ ms}$  is \_\_\_\_\_ mA (rounded off to two decimal places).

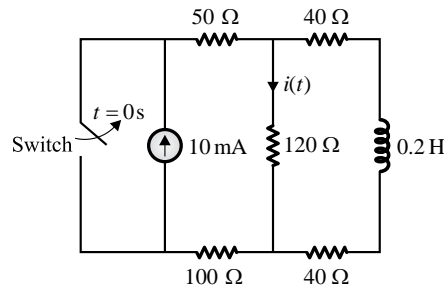

Ans. 4.60 to 5.00

Question 64

A signal  $V_M = 5\sin(\pi t/3) \text{ V}$  is applied to the circuit consisting of a switch  $S$  and capacitor  $= 0.1 \mu \text{ F}$ , as shown in the figure. The output  $V_x$  of the circuit is fed to an ADC having an input impedance consisting of a  $10 \text{ M}\Omega$  resistance in parallel with a  $0.1 \mu \text{ F}$  capacitor. If  $S$  is opened at  $t = 0.5 \text{ s}$ , the value of  $V_x$  at  $t = 1.5 \text{ s}$  will be \_\_\_\_\_ V (rounded off to two decimal places).

Note : Assume all components are ideal.

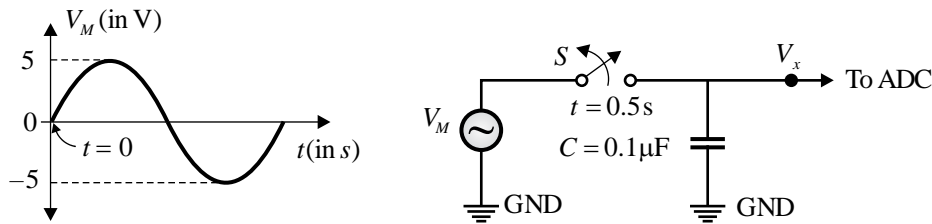

Ans. 1.50 to 1.54

Question 65

For the circuit shown in the figure, the active power supplied by the source is \_\_\_\_\_ W (rounded off to one decimal place).

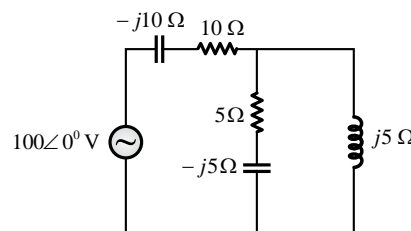

Ans. 590 to 610

