

General Aptitude Part

Q.1 to Q.5 Carry One Mark Each

Question 1

Is there any good show _____ television tonight?

Select the most appropriate option to complete the above sentence.

- (A) in (B) at
(C) within (D) on

Ans. (D)

Question 2

As the police officer was found guilty of embezzlement, he was _____ dismissed from the service in accordance with the Service Rules.

Select the most appropriate option to complete the above sentence.

- (A) sumptuously (B) brazenly
(C) unintentionally (D) summarily

Ans. (D)

Questions 3

The sum of the following infinite series is

$$\frac{1}{1!} + \frac{1}{2!} + \frac{1}{3!} + \frac{1}{4!} + \frac{1}{5!} + \dots$$

- (A) π (B) $1+e$
(C) $e-1$ (D) e

Ans. (C)

Question 4

A thin wire is used to construct all the edges of a cube of 1 m side by bending, cutting and soldering the wire. If the wire is 12 m long, what is the minimum number of cuts required to construct the wire frame to form the cube?

- (A) 3 (B) 4
(C) 6 (D) 12

Ans. (A)

Question 5

The figures, I, II and III are parts of a sequence. Which one of the following option comes next in the sequence is IV?

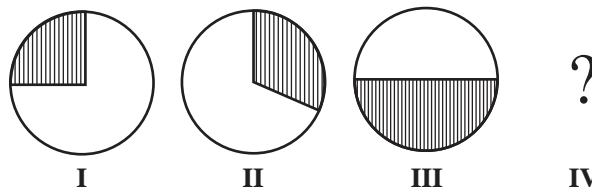

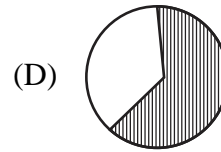
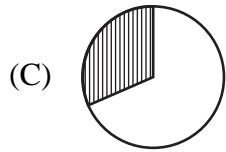
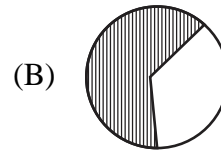
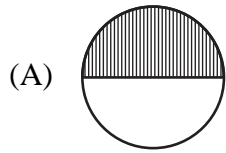

Ans. (B)

Q.6 to Q.10 Carry Two Marks Each

Question 6

"Why do they pull down and do away with crooked streets, I wonder, which are my delight, and hurt no man living? Every day the wealthier nations are pulling down one or another in their capitals and their great towns: they do not know why they do it; neither do I. It ought to be enough, surely, to drive the great broad ways which commerce needs and which are the life-channels of a modern city, without destroying all history and all the humanity in between: the islands of the past."

(From Hilaire Belloc's "The Crooked Streets")

Based only on the information provided in the above passage, which one of the following statements is true?

- (A) The author of the passage takes delight in wondering.
- (B) The wealthier nations are pulling down the crooked streets in their capitals.
- (C) In the past, crooked streets were only built on islands.
- (D) Great broad ways are needed to protect commerce and history.

Ans. (B)

Questions 7

Rohit goes to a restaurant for lunch at about 1 PM. When he enters the restaurant, he notices that the hour and minute hands on the wall clock are exactly coinciding. After about an hour, when he leaves the restaurant, he notices that the clock hands are again exactly coinciding. How much time (in minutes) did Rohit spend at the restaurant?

- (A) $64\frac{6}{11}$
- (B) $66\frac{5}{13}$
- (C) $65\frac{5}{11}$
- (D) $66\frac{6}{13}$

Ans. (C)

Question 8

A color model is shown in the figure with color codes: Yellow (Y), Magenta (M), Cyan (Cy), Red (R), Blue (Bl), Green (G), and Black (K). Which one of the following options displays the color codes that are consistent with the color model?

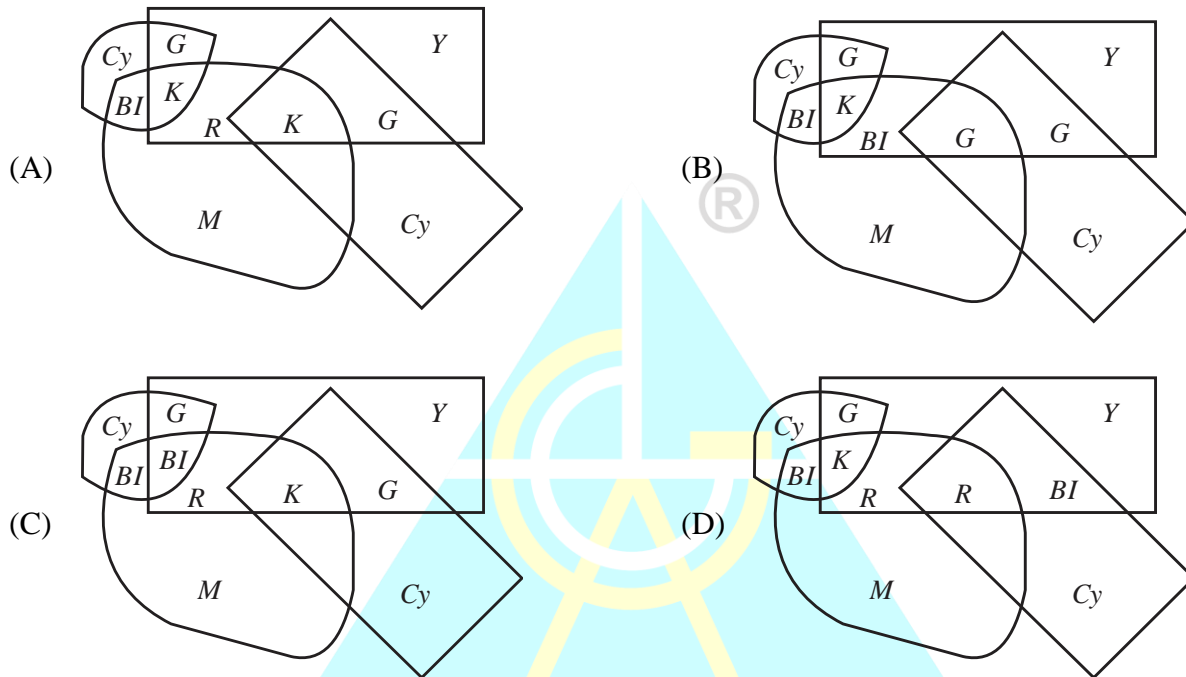
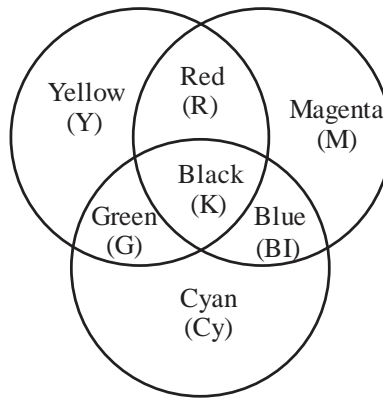

Ans. (A)

Question 9

A circle with center at $(x, y) = (0.5, 0)$ and radius = 0.5 intersects with another circle with center at $(x, y) = (1, 1)$ and radius = 1 at two points. One of the points of intersection (x, y) is :

- (A) (0, 0) (B) (0.2, 0.4)
(C) (0.5, 0.5) (D) (1, 2)

Ans. (B)

Question 10

An object is said to have an n -fold rotational symmetry if the object, rotated by an angle of $\frac{2\pi}{n}$, is identical to the original.

Which one of the following objects exhibits 4-fold rotational symmetry about an axis perpendicular to the plane of the screen?

Note : The figures shown are representative.

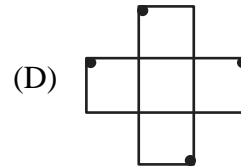
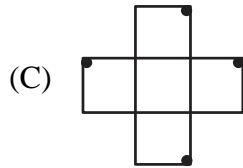
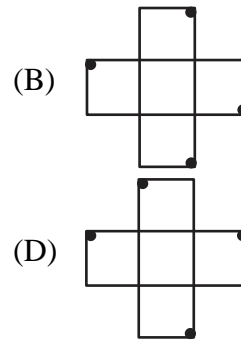
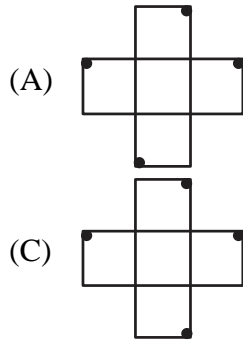

Ans. (B)

Technical Part

Q.11 to Q.35 Carry One Mark Each

Question 11

Suppose λ is an eigenvalue of matrix A and x is the corresponding eigenvector. Let x also be an eigenvector of the matrix $B = A - 2I$, where I is the identity matrix. Then, the eigenvalue of B corresponding to the eigenvector x is equal to

- (A) λ (B) $\lambda + 2$
 (C) 2λ (D) $\lambda - 2$

Ans. (D)

Question 12

Let $A = \begin{bmatrix} 1 & 1 \\ 1 & 3 \\ -2 & -3 \end{bmatrix}$ and $b = \begin{bmatrix} b_1 \\ b_2 \\ b_3 \end{bmatrix}$. For $Ax = b$ to be solvable, which one of the following options is the correct condition on b_1, b_2 and b_3 .

- (A) $b_1 + b_2 + b_3 = 1$ (B) $3b_1 + b_2 + 2b_3 = 0$
 (C) $b_1 + 3b_2 + b_3 = 2$ (D) $b_1 + b_2 + b_3 = 2$

Ans. (B)

Question 13

Which one of the following options is the correct Fourier series of the periodic function $f(x)$ described below:

$$f(x) = \begin{cases} 0 & \text{if } -2 < x < -1 \\ 2k & \text{if } -1 < x < 1; \text{ period} = 4 \\ 0 & \text{if } 1 < x < 2 \end{cases}$$

- (A) $f(x) = \frac{k}{2} + \frac{2k}{\pi} \left(\cos \frac{\pi}{2} x - \frac{1}{3} \cos \frac{3\pi}{2} x + \frac{1}{5} \cos \frac{5\pi}{2} x - + \dots \right)$
 (B) $f(x) = \frac{k}{2} + \frac{2k}{\pi} \left(\sin \frac{\pi}{2} x - \frac{1}{3} \sin \frac{3\pi}{2} x + \frac{1}{5} \sin \frac{5\pi}{2} x - + \dots \right)$

(C) $f(x) = k + \frac{4k}{\pi} \left(\cos \frac{\pi}{2} x - \frac{1}{3} \cos \frac{3\pi}{2} x + \frac{1}{5} \cos \frac{5\pi}{2} x - + \dots \right)$

(D) $f(x) = k + \frac{4k}{\pi} \left(\sin \frac{\pi}{2} x - \frac{1}{3} \sin \frac{3\pi}{2} x + \frac{1}{5} \sin \frac{5\pi}{2} x - + \dots \right)$

Ans. (C)**Question 14**

X is the random variable that can take any one of the values 0, 1, 7, 11 and 12. The probability mass function for X is

$$P(X = 0) = 0.4, P(X = 1) = 0.3, P(X = 7) = 0.1,$$

$$P(X = 11) = 0.1, P(X = 12) = 0.1$$

Then, the variance of X is

(A) 20.81

(B) 28.40

(C) 31.70

(D) 10.89

Ans. (A)**Question 15**

As per IS 456:2000 provisions for two-way slabs with continuous edges, the longitudinal steel reinforcement to be provided in the edge strip is based on

(A) the calculated minimum bending moment

(B) the area of longitudinal steel provided in the middle strip in the shorter span

(C) the area of longitudinal steel provided in the middle strip in the longer span

(D) the prescribed minimum cross-sectional area of longitudinal steel for slabs

Ans. (D)**Question 16**

Identify the FALSE statement from the following options :

(A) The compressive strength of a concrete test specimen can vary depending on its shape and size

(B) Air-dried and saturated test specimens show the same compressive strength for concrete

(C) Curing conditions, such as temperature and relative humidity, can influence the compressive strength of concrete

(D) Compressive strength depends on the water-to-binder ratio used in the concrete mixture

Ans. (B)**Question 17**

The results of a consolidated drained triaxial test on a normally consolidated clay are shown in the figure. The angle of internal friction is

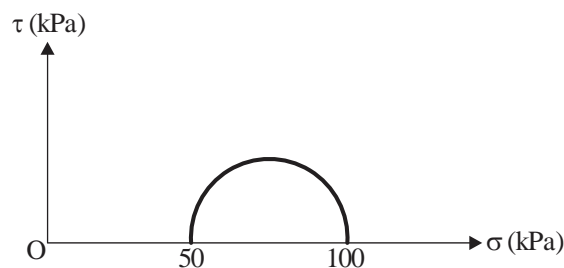

(A) $\sin^{-1}\left(\frac{1}{2}\right)$

(B) $\sin^{-1}\left(\frac{1}{3}\right)$

(C) $\sin^{-1}\left(\frac{2}{3}\right)$

(D) $\sin^{-1}\left(\frac{3}{4}\right)$

Ans. (B)**Question 18**

The standard plasticity chart for the classification of a fine-grained soil is shown in the figure. As per the Indian standard soil classification system, X represents

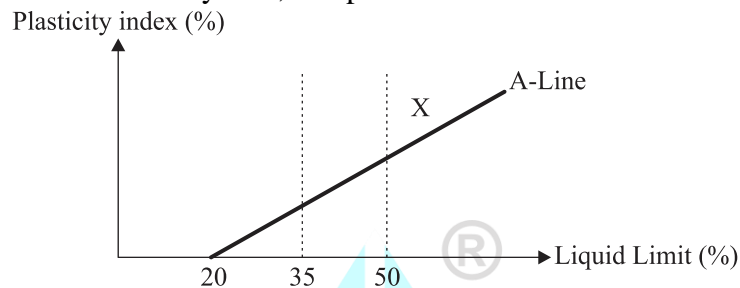

- (A) inorganic clay with medium plasticity
 (B) inorganic silt with medium plasticity
 (C) inorganic clay with high plasticity
 (D) inorganic silt with high compressibility

Ans. (C)**Question 19**

For a flowing fluid, a dimensionless combination of velocity (V), length scale (l), and acceleration due to gravity (g) would be

(A) $\frac{V^2}{gl}$

(B) $\frac{Vg}{l}$

(C) $\frac{gl^2}{V}$

(D) $\frac{l}{V^2g}$

Ans. (A)**Question 20**

To derive the total flood hydrograph at a catchment outlet from an isolated storm, the order in which the following methods are applied, from the first method to the last method,

- P. Obtaining the hyetograph Q. Addition of baseflow
 R. Estimation of initial and infiltration losses S. Application of unit hydrograph
- (A) PRSQ (B) PQRS
 (C) RPSQ (D) PSQR

Ans. (A)**Questions 21**

Fecal Coliform (FC) concentration in river water was measured as 10780 cfu/100 ml. The FC concentration after the conventional water treatment, but before chlorination, was measured as 23 cfu/100 ml. The 'Log Kill' (inactivation) of FC due to the conventional water treatment is closest to

- (A) 4.00 (B) 2.50
(C) 2.67 (D) 3.00

Ans. (C)

Question 22

A hydrocarbon (C_nH_m) is burnt in air ($O_2 + 3.78N_2$). The stoichiometric fuel to air mass ratio for this process is

Note : Atomic weight : C(12), H(1)

Effective molecular weight : Air(28.8)

Ignore any conversion of N_2 in air to the oxides of nitrogen (NO_x)

- (A) $0.0291 \frac{(4n+m)}{(12n+m)}$ (B) $34.42 \frac{(12n+m)}{(4n+m)}$
(C) $34.42 \frac{(4n+m)}{(12n+m)}$ (D) $0.0291 \frac{(12n+m)}{(4n+m)}$

Ans. (D)

Question 23

All the vehicles that come during a particular peak hour come during a 10-minute period within this hour. The 15-minute peak hour factor for this peak hour is

- (A) 0.25 (B) 0.167
(C) 0.75 (D) 1.0

Ans. (A)

Question 24

In the context of testing bitumen, which one of the following statements is FALSE:

- (A) The depth of penetration of needle in the standard penetration test is measured in the units of one-tenth of millimeter
(B) Softening point is measured using a ring and ball apparatus
(C) Softening point is measured in the units of time
(D) Ductility is measured in the units of length

Ans. C

Question 25

The maximum degree of the curve that can be used for railways in a mountainous region

- (A) 10 (B) 20
(C) 50 (D) 40

Ans. (D)

Question 26

If the horizontal distance between a staff point and the point of observation is d , the error due to the curvature of earth is proportional to

- (A) d (B) $\frac{1}{d}$

(C) d^2

(D) $\frac{1}{d^2}$

Ans. (C)**Question 27**

If the quadrantal bearing of a line is $N30^{\circ}W$, then the whole circle bearing of the line is

(A) 120°

(B) 210°

(C) 300°

(D) 330°

Ans. (D)**Question 28**

Which of the following equations belong/belongs to the class of second-order, linear, homogeneous partial differential equations :

(A) $\frac{\partial^2 u}{\partial t^2} = c^2 \left(\frac{\partial^2 u}{\partial x^2} + \frac{\partial^2 u}{\partial y^2} \right) + xy$

(B) $\frac{\partial^2 u}{\partial x^2} + \frac{\partial^2 u}{\partial y^2} + \frac{\partial^2 u}{\partial z^2} = 0$

(C) $\frac{\partial u}{\partial t} = c \frac{\partial u}{\partial x}$

(D) $\left(\frac{\partial^2 u}{\partial t^2} \right)^2 = c^2 \frac{\partial^2 u}{\partial x^2}$

Ans. (B)**Question 29**

Consider the frame shown in the figure under the loading of 100 kN.m couples at the joints B and G. Considering only the effects of flexural deformations, which of the following statements is/are true :

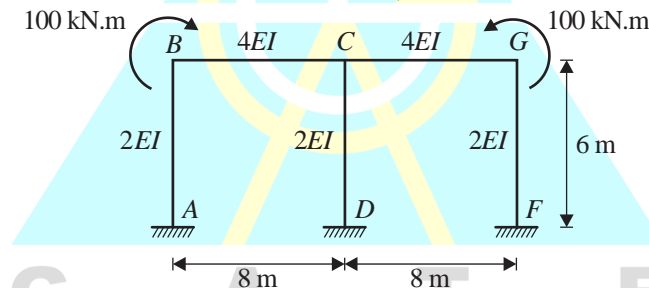

(A) Axial force is zero in the member CD

(B) Shear force is zero in the member CD

(C) There is no rotation in the joint C

(D) The magnitude of bending moment developed in the member BC at the end C is more than 50 kN.m

Ans. (B, C)**Question 30**

For the Bernoulli's equation to be applicable in a fluid flow situation, which of the following conditions is/are to be satisfied:

(A) Fluid should be frictionless

(B) Fluid should be incompressible

(C) Flow should be steady

(D) Flow should be rotational

Ans. (A, B, C)**Questions 31**

The Surface Overflow Rate (SOR) in a rectangular sedimentation tank is $45 \text{ m}^3/\text{m}^2/\text{d}$. Minimum diameters of spherical inorganic and organic particles expected to be completely removed in this tank are calculated. Assume that Stoke's law is applicable. Which of the following options is/are correct

Specific gravity of inorganic particles = 2.65

Specific gravity of organic particles = 1.20

Acceleration due to gravity (g) = 9.81 m/s^2

Kinematic viscosity (ν) = $1 \times 10^{-6} \text{ m}^2/\text{s}$

- (A) Minimum diameter of inorganic particles is $24 \mu\text{m}$
- (B) Minimum diameter of organic particles is $69 \mu\text{m}$
- (C) Minimum diameter of inorganic particles is $15 \mu\text{m}$
- (D) Minimum diameter of organic particles is $55 \mu\text{m}$

Ans. (A, B)

Question 32

Aeration is employed as a treatment option for the removal of several pollutants from contaminated water.

Identify the pollutant(s), where aeration is employed as a part of their removal:

- (A) Iron
- (B) Cadmium
- (C) Manganese
- (D) Zinc

Ans. (A, C)

Question 33

If the weights retained on the 2.36 mm, 1.18 mm, $600 \mu\text{m}$, and $300 \mu\text{m}$ sieves are 30%, 35%, 15%, and 20%, respectively, of the total weight of an aggregate sample, then the fineness modulus of the sample is _____ (rounded off to 2 decimal places).

Ans. 3.75 [3.74 to 3.76]

Question 34

A water resources project with an expected life of 25 years has to be designed for an acceptable risk of 5% against a design flood. The return period for the design flood (in years) is _____ (rounded off to the nearest integer).

Ans. 488 [485 to 490]

Questions 35

Road A and Road B are joined by a circular horizontal curve of radius 200 m as shown in the figure. Road A and Road B are tangential to the curve at the points C and D, respectively. Had the curve not been there, straight roads A and B would have met at the point E. The distance from C to E is 92 m. The value of angle θ (in degrees) is _____ (rounded off to 1 decimal place).

Note : The value of angle θ is to be calculated only from the consideration of Euclidean geometry and the data given in the problem.

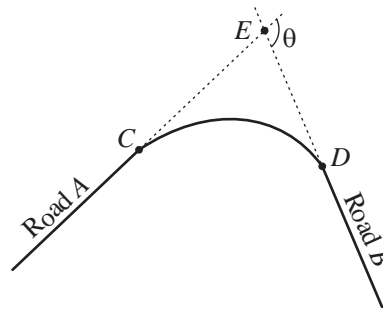

Ans. 49.40 [48 to 51]

Q.36 to Q.65 Carry Two Marks Each

Question 36

The value of $\lim_{x \rightarrow \infty} (x - \sqrt{x^2 + x})$ is equal to

- (A) -1 (B) -0.5
(C) -2 (D) 0

Ans. (B)

Question 37

In the rigid-jointed frame shown in the figure, the distribution factor of the member AD is closest to

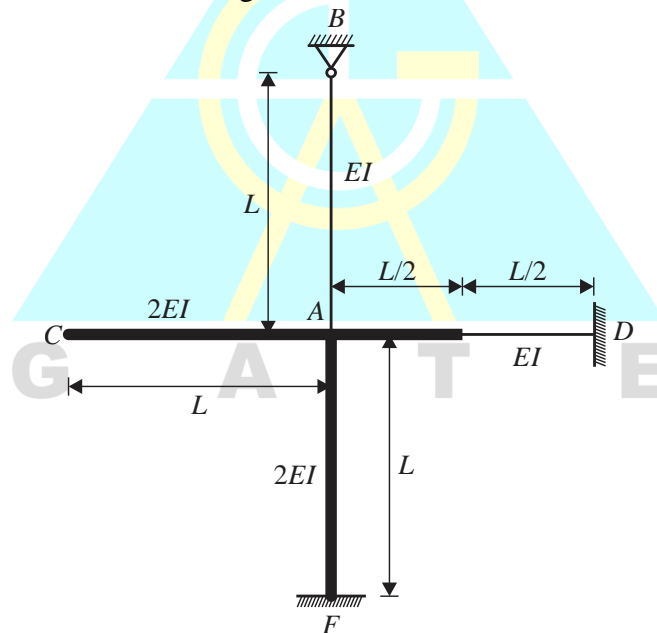

- (A) 0.254 (B) 0.267
(C) 0.398 (D) 0.421

Ans. (C)

Question 38

In an oedometer apparatus a specimen of fully saturated clay has been consolidated under a vertical pressure of 100 kPa and is at equilibrium state. Immediately on increasing the vertical pressure to 150 kPa, the effective stress σ' and excess pore water pressure Δu will be

- (A) Bending moment is zero between the points A and C
- (B) There is a sudden jump in shear force at the point D
- (C) There is a sudden jump in bending moment at the point E
- (D) Bending moment is zero somewhere between the points D and E

Ans. (A, D)

Question 42

In the context of construction project management, which of the following statements is/are true :

- (A) A dummy activity will consume time and resources
- (B) The programme evaluation and review technique (PERT) is best suited for projects with large uncertainties in the duration of activities
- (C) A Gantt chart is commonly used for identifying the 'critical path' of activities in a project
- (D) Free float is the amount of time by which the start of an activity can be delayed without causing a delay in the start of a following activity

Ans. (B, D)

Question 43

Lacey's regime equations, followed in India for making scour calculations while designing hydraulic structures across alluvial channels, are given below. Regarding these equations, which of the following statements is/are true :

$$D = 0.470 \times \left[\frac{Q}{f_s} \right]^{1/3}$$

$$P = 4.75 \times \sqrt{Q}$$

$$f_s = 1.76 \sqrt{d}$$

where, Q is discharge and f_s is silt factor

- (A) D is the depth of scour below the existing riverbed
- (B) P is the Lacey's waterway width
- (C) d is the average grain size diameter of the bed material in centimetres
- (D) D is the depth of scour below the design flood level

Ans. (B, D)

Question 44

MgCl₂ and CaSO₄ salts are added to 1 litre of distilled deionized water and mixed until completely dissolved. Total Dissolved Solids (TDS) concentration is 500 mg/l, and Total Hardness (TH) is 400 mg/l (as CaCO₃). The amounts of MgCl₂ and CaSO₄ added are calculated (rounded off to the nearest integer). Which of the following options is/are true :

Atomic weights: Ca(40), Mg(24), S(32), O(16), Cl(35.5), C(12)

- (A) Amount of MgCl₂ added is 143 mg
- (B) Amount of CaSO₄ added is 357 mg
- (C) Amount of MgCl₂ added is 103 mg
- (D) Amount of CaSO₄ added is 397 mg

Ans. (C, D)

Question 45

A facultative pond system is employed for wastewater treatment. Which of the following statements is/are true :

- (A) The dissolved oxygen concentration will be high during daytime compared to night-time
- (B) The pH will be high during daytime compared to night-time
- (C) The dissolved oxygen concentration will be low during daytime compared to night-time
- (D) The pH will be low during daytime compared to night-time

Ans. (A, B)

Question 46

Organic fraction of municipal solid waste (OFMSW) with bulk density of 315 kg/m^3 and water content of 30% is mixed with municipal sludge of bulk density 700 kg/m^3 and water content of 70%, such that the water content of the mixture is 40%. The amount (in kg) of sludge to be mixed per kg of OFMSW (rounded off to 2 decimal places) and the density of the mixture (in kg/m^3) (rounded off to the nearest integer) are calculated.

Which of the following options is/are true :

- (A) 0.33 kg of sludge added per kg of OFMSW
- (B) Density of the mixture is 365 kg/m^3
- (C) 0.66 kg of sludge added per kg of OFMSW
- (D) Density of the mixture is 450 kg/m^3

Ans. (A, B)

Question 47

Let y be the solution of the initial value problem $y'' + 0.8y' + 0.16y = 0$, where $y(0) = 3$ and $y'(0) = 4.5$. Then $y(1)$ is equal to _____ (rounded off to 1 decimal place).

Ans. 5.83 [5.7 to 5.9]

Question 48

The maximum value of the function $h(x) = -x^3 + 2x^2$ in the interval $[-1, 1.5]$ is equal to _____. (rounded off to 1 decimal place)

Ans. 3 [2.9 to 3.1]

Question 49

Consider the differential equation given below. Using the Euler method with the step size (h) of 0.5, the value of y at $x = 1.0$ is equal to _____ (rounded off to 1 decimal place).

$$\frac{dy}{dx} = y + 2x - y^2; \quad y(0) = 1 \quad (0 \leq x < \infty)$$

Ans. 2.6

Question 50

For the beam and loading shown in the figure, the second derivative of the deflection curve of the beam at the mid-point of AC is given by $\frac{\alpha M_0}{8EI}$. The value of α is _____ (rounded off to the nearest integer).

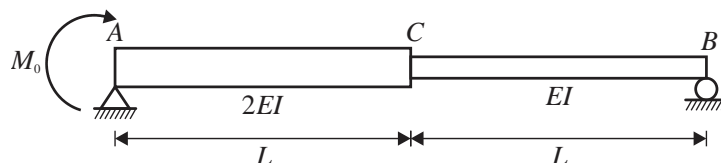

Ans. 3 [3 to 3]

Question 51

Consider the rigid bar ABC supported by the pin-jointed links BD and CE and subjected to a load P at the end A, as shown in the figure. The axial rigidities of BD and CE are 22500 kN and 15000 kN, respectively. If CE elongates by 5 mm due to the load P, the magnitude of the downward deflection (in mm) of the end A would be _____ (rounded off to the nearest integer).

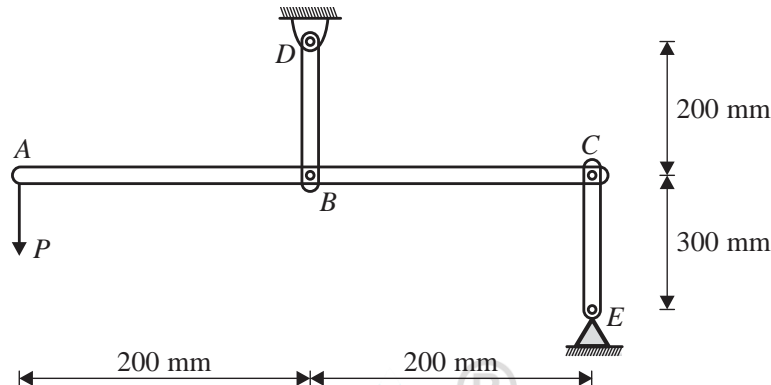

Ans. 14 [14 to 14]

Question 52

Consider a reinforced concrete beam section of 300 mm width and 700 mm depth. The beam is reinforced with the tension steel of 2000 mm² area at an effective cover of 50 mm. Concrete in the tension zone is assumed to be cracked. Assume the modular ratio of 12 and Young's modulus of 200 GPa for steel. When the extreme fibre in the compression zone undergoes the strain of 0.0004 due to the applied bending moment, the stress in the steel (in MPa) is _____ (rounded off to the nearest integer).

Ans. 126 [125 to 127]

Question 53

Consider the beam section shown in the figure, with \bar{y} indicating the depth of neutral axis (NA). The section is only subjected to an increasing bending moment. It is given that $\bar{y} = 18.75$ mm, when the section has not yielded at the top and bottom fibres. Further, \bar{y} decreases to 5 mm, when the entire section has yielded. The shape factor of the section is _____ (rounded off to 2 decimal places).

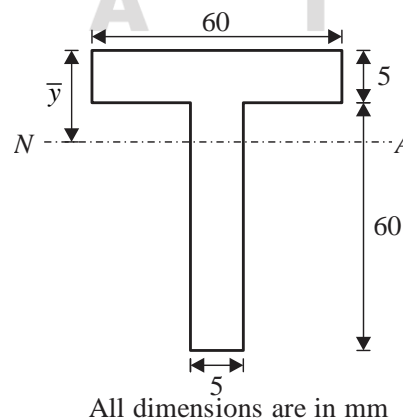

Ans. 1.81 [1.8 to 1.82]

Question 54

Consider the built-up column made of two I-sections as shown in the figure, with each batten plate bolted to a component I-section of the column through 6 black bolts. Each connection of the batten plate

with the component section is to be designed for a longitudinal shear of 70 kN and moment of 10 kN.m. The minimum bolt value required (in kN) is _____ (rounded off to the nearest integer).

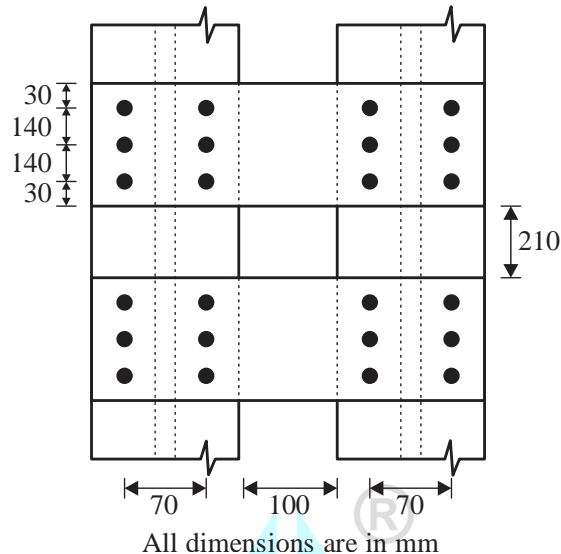

Ans. 23 [21 to 24]

Question 55

A cut slope is made in a silty clay soil for a new road project, as shown in the figure. The locations of ground water table (GWT) and potential failure surface are shown in the figure. After the cut is made, the excess pore water pressure is fully dissipated, and the shear stress at the point A is 60 kN/m². The factor of safety at the point A for long-term stability is _____ (rounded off to 2 decimal places).

Note :

Shear strength properties of silty clay : $c' = 15 \text{ kN/m}^2$, $\phi' = 15^\circ$, and $c_u = 75 \text{ kN/m}^2$

Unit weight of soil above the GWT (γ) = 19 kN/m³

Unit weight of soil below the GWT (γ_{sat}) = 20 kN/m³

Unit weight of water (γ_w) = 9.81 kN/m³

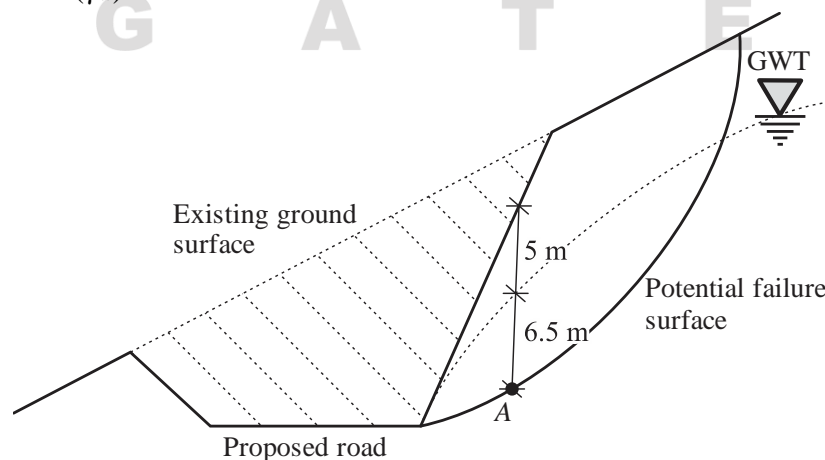

Ans. 0.97 [0.96 to 0.98]

Question 56

A $6\text{ m} \times 6\text{ m}$ square footing constructed in clay is subjected to a vertical load of 2500 kN at its centre. The base of the footing is 2 m below the ground surface, as shown in the figure. The footing is made of 2 m thick concrete. The ground water table is at a great depth. Considering Terzaghi's bearing capacity theory, the factor of safety of footing against the bearing capacity failure is _____ (rounded off to 2 decimal places).

Note :

Unit of concrete = 24 kN/m^3

Properties of clay $c = 50\text{ kN/m}^3$, $\phi = 0^\circ$ and $\gamma = 19\text{ kN/m}^3$

For $\phi = 0^\circ$: $N_c = 5.7$, $N_q = 1$, $N_\gamma = 0$

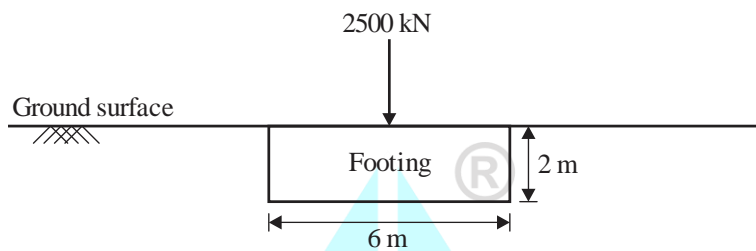

Ans. 4.66 [4.62 to 4.70]

Question 57

A clayey soil has a moisture content of 18% , a specific gravity of soil solids of 2.74 , and a degree of saturation of 65% . The soil soaks up water during a rain event, and the degree of saturation increases to 85.2% . The change of the volume during the soaking is negligible. The new moisture content (in %) of the soil will be _____ (rounded off to 2 decimal places).

Ans. 23.59 [23.3 to 23.63]

Question 58

A single pile with 450 mm diameter has been driven into a homogeneous clay layer, which has an undrained cohesion (c_u) of 20 kPa and unit weight of 18 kN/m^3 . The ground water table is found to be at the surface of the clay layer. The adhesion factor (α) of the soil is 0.95 and bearing capacity factor (N_c) is 9 . The pile is supporting a column load of 144 kN with a factor of safety of 3.0 against ultimate axial pile capacity in compression.

The required embedment depth of the pile (in m) is _____ (rounded off to the nearest integer).

Ans. 15 [15 to 15]

Question 59

Two soils of permeabilities k_1 and k_2 are placed in a horizontal flow apparatus, as shown in the figure. For Soil 1, $L_1 = 50\text{ cm}$ and $k_1 = 0.055\text{ cm/s}$, for Soil 2, $L_2 = 30\text{ cm}$ and $k_2 = 0.035\text{ cm/s}$. The cross sectional area of the horizontal pipe is 100 cm^2 , and the head difference (Δh) is 150 cm . The discharge (in cm^3/s) through the soils is _____ (rounded off to 2 decimal places).

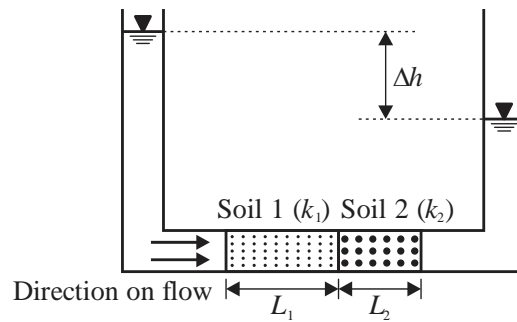

Ans. 8.49 [8.48 to 8.56]

Question 60

A hydraulic jump is formed in a 5 m wide rectangular channel, which has a horizontal bed and is carrying a discharge of $15 \text{ m}^3/\text{s}$. The depth of water upstream of the jump is 0.5 m. The power dissipated by the jump (in kW) is _____ (rounded off to the nearest integer).

Note :

Acceleration due to gravity = 9.81 m/s^2

Density of water = 1000 kg/m^3

Kinetic energy correction factor = 1.0

Ans. 72 [69 to 75]

Question 61

A symmetrical trapezoidal canal is 100 km long. The bottom width is 10 m and the side slope is 1 Horizontal: 1 Vertical. The average flow depth in the canal is 2.5 m throughout the month of April. The measurement from a Class-A evaporimeter in the vicinity of the canal indicated an average evaporation rate of 0.5 cm/day in April. The volume of water evaporated from the canal (in m^3) in the month of April is close to _____ $\times 10^3$ (rounded off to 1 decimal place).

Ans. 157.5 (155 to 160)

Question 62

A 5.0 m wide rectangular channel carries a discharge of $10 \text{ m}^3/\text{s}$ at a depth of 1.5 m under uniform flow. To produce critical flow conditions without affecting the upstream conditions, the channel bottom elevation should be raised (in m) by _____ (rounded off to 2 decimal places).

Assume that there is no loss of head at the raise, kinetic energy correction factor is 1.0, and acceleration due to gravity is 9.81 m/s^2 .

Ans. 0.48 [0.45 to 0.51]

Question 63

A one-way, single lane road has traffic that consists of 30% trucks and 70% cars. The speed of trucks (in km/h) is a uniform random variable on the interval (30, 60), and the speed of cars (in km/h) is a uniform random variable on the interval (40, 80). The speed limit on the road is 50 km/h. The percentage of vehicles that exceed the speed limit is _____ (rounded off to 1 decimal place).

Note: X is a uniform random variable on the interval (α, β) , if its probability density function is given by

$$f(x) = \begin{cases} \frac{1}{\beta - \alpha} & \alpha < x < \beta \\ 0 & \text{otherwise} \end{cases}$$

Ans. 62.5 [61 to 63]

Question 64

In levelling between two points A and B on the opposite banks of a river, the readings are taken by setting the instrument both at A and B, as shown in the table. If the RL of A is 150.000 m, the RL of B (in m) is _____ (rounded off to 3 decimal places).

Level position	Staff readings	
	A	B
A	1.800	1.350
B	1.450	0.950

Ans. 150.475 [150.470 to 150.480]

Question 65

During determination of the bulk specific gravity of compacted bituminous specimen, the mass in air of the specimen is 1260 g and volume is 525 cm³. The density of water is 1.0 g/cm³. The theoretical maximum specific gravity of mix is 2.510.

The percentage air voids in the compacted specimen is _____ (rounded off to 2 decimal places).

Ans. 4.38 [4.22 to 4.56]

