

General Aptitude

Q.1 to Q.5 Carry One Mark Each

Q.1 Suresh said, "I did it yesterday."

Which one of the following options is the correct form of this sentence in indirect speech?

- (A) Suresh said that I did it yesterday.
- (B) Suresh says I did it yesterday.
- (C) Suresh says that he did it the day before.
- (D) Suresh said that he had done it the day before.

Ans. D

Q.2 To continue the sequence of tiles shown, the tile indicated by the question mark should be

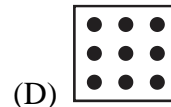
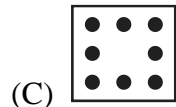
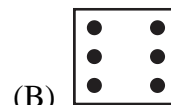
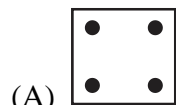
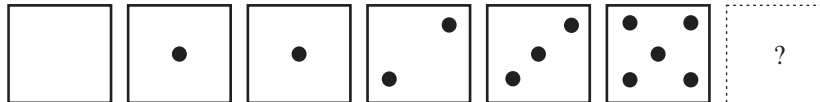

Ans. C

Q.3 Consider an art gallery whose walkways are shown as lines in the diagram. A black dot represents a junction of two walkways. A guard may be placed at a junction to watch over the walkways that join at that junction. The minimum number of guards needed to watch all the walkways is _____.

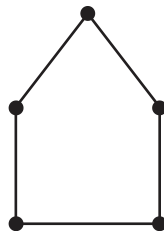

- (A) 2 (B) 3 (C) 4 (D) 5

Ans. B

Q.4 The 2nd of June is a Thursday in a certain year. Which day of the week is the 3rd of July in that year?

- (A) Thursday (B) Friday (C) Saturday (D) Sunday

Ans. D

Q.5 A coin with heads facing up is shown (*H*) and a coin with tails facing up is shown as (*T*).

Six coins are placed in the Starting Arrangement, as shown in the figure below. A "step" is defined as interchanging a pair of adjacent coins without flipping them. The minimum number of steps needed to go from the Starting Arrangement to the Final Arrangement, as shown in the figure, is_____.



- (A) 3 (B) 6 (C) 9 (D) 12

Ans. C

Q.6 to Q.10 Carry Two Marks Each

Q.6 Exacerbate : Mitigate :: _____.

Choose the option with the correct pair of words to fill the blank.

- (A) Aggravate: Alleviate (B) Alleviate: Precipitate
(C) Aggravate: Precipitate (D) Emancipate: Exonerate

Ans. A

Q.7 A paper shown in Panel I is folded along the dashed lines (- - -) to construct a cube. The shaded regions shown in Panel I appear on the outer surface of the cube. Referring to cubes shown in Panel II, which one of the options is correct?

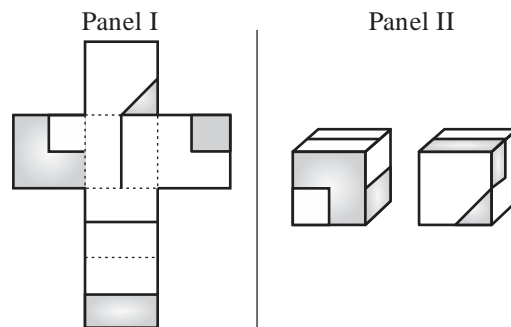

- Only (i) can correspond to the unfolded cube in Panel I.
Only (ii) can correspond to the unfolded cube in Panel I.
Both (i) and (ii) can correspond to the unfolded cube in Panel I.
Neither (i) nor (ii) can correspond to the unfolded cube in Panel I.

Ans. B

Q.8 In a population, patients who have high cholesterol also have high blood-pressure (BP). Some patients with high BP also have diabetes. There are no patients who have both high cholesterol and diabetes. Furthermore,

1. The total number of patients with at least one of these conditions is 75,
2. The number of patients with high cholesterol is 10,
3. The number of patients with high BP is 45, and
4. The number of patients with only high BP and no other conditions is 20.

Then the number of patients who have both diabetes and high BP is.

- (A) 0 (B) 15 (C) 20 (D) 10

Ans. B

Q.9 Four people P, Q, R and S, of different ages, make the following observations.

P - I am younger than S.

Q - I am neither the youngest nor the oldest.

R - P is older than me.

Based on these observations, the youngest person is_____.

(A) P

(B) Q

(C) R

(D) S

Ans. C

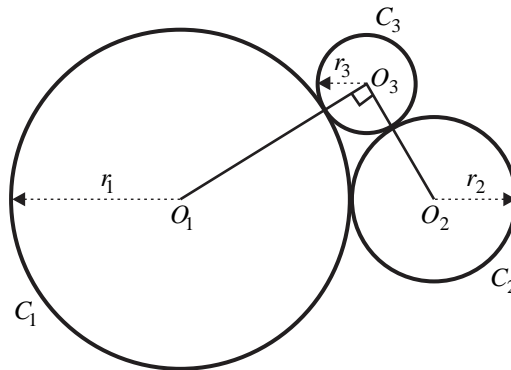
Q.10 Circles C_1, C_2 and C_3 , with centres O_1, O_2 and O_3 and radii r_1, r_2 and r_3 , respectively, touch each other as shown in the following figure. Given $r_1 = 2\text{cm}$, $r_2 = 1\text{cm}$ and the angle $\angle O_1O_3O_2$ is 90° , $r_3 =$ _____ cm.(A) $\frac{1}{2}(-3 + \sqrt{17})$ (B) $\frac{1}{2}(3 + \sqrt{17})$ (C) $\frac{1}{2}(-2 + \sqrt{17})$ (D) $\frac{1}{2}(-3 + 2\sqrt{17})$

Ans. A

Technical Section

Q.11 to Q.35 Carry One Mark Each

Q.11 A matrix $P \in R^{3 \times 3}$ satisfies $P^3 - 4P^2 + 5P - 2I = 0$ where I is a 3×3 identity matrix.

The set of all possible eigenvalues of matrix P is_____.

[Engineering Mathematics, Linear Algebra]

(A) {1, 2, 3}

(B) {1}

(C) {1, 2}

(D) {2}

Ans. C

Q.12 Which one among the following statements is true for the function $f(x) = x|x|$?(A) $f(x)$ discontinuous but not differentiable at $x = 0$ (B) $f(x)$ discontinuous and differentiable at $x = 0$

- (C) $f(x)$ continuous but not differentiable at $x = 0$
(D) $f(x)$ is continuous and differentiable at $x = 0$

[Engineering Mathematics, Maxima & Minima]

Ans. D

Q.13 Consider a function $f(z) = z^2 + z + 1$ where $z \in \mathbb{C}$ is a complex variable. A simple closed contour γ in z -plane encloses the point $z = 1 + 0j$.

The value of integral $\oint_{\gamma} \frac{f(z)}{z-1} dz =$ _____.

[Engineering Mathematics, Complex Variable]

- (A) $6\pi j$ (B) $3\pi j$ (C) $12\pi j$ (D) πj

Ans. A

Q.14 Consider a matrix

$$A = \begin{bmatrix} 1 & 0 & 2 \\ -1 & 1 & 0 \\ 0 & 1 & 2 \end{bmatrix}$$

$$\text{Let } b = \begin{bmatrix} 1 \\ 3 \\ 0 \end{bmatrix} \text{ and } x = \begin{bmatrix} x_1 \\ x_2 \\ x_2 \end{bmatrix}$$

The number of solutions to the linear system of equations $Ax = b$ is _____.

- (A) 0 (B) 1 (C) 6 (D) Infinitely many

[Engineering Mathematics, Linear Algebra]

Ans. A

Q.15 An electric field has a potential of $V(x, y, z) = \sqrt{x^2 + y^2 + z^2}$ V.

A charge of 1 coulomb placed at $(\hat{i} + \hat{j} + \hat{k})$ experiences a force of $\vec{F} = (a\hat{i} + b\hat{j} + c\hat{k})$ N.

The value of (a, b, c) are _____.

- (A) $a = \frac{1}{\sqrt{3}}, b = \frac{1}{\sqrt{3}}, c = \frac{1}{\sqrt{3}}$ (B) $a = \frac{1}{3}, b = \frac{1}{3}, c = \frac{1}{3}$
(C) $a = 0, b = 1, c = \frac{1}{\sqrt{3}}$ (D) $a = 0, b = 1, c = \frac{1}{3}$

[Engineering Mathematics, Vector Calculus]

Ans. A

Q.16 The RLC filter shown below acts as a_____.

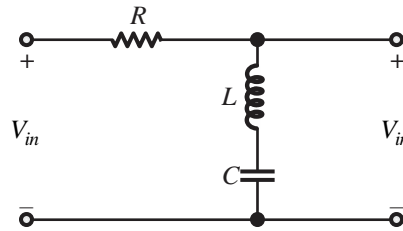

- (A) Low pass filter
(B) High pass filter
(C) Band pass filter
(D) Band stop filter

Ans. D

Q.17 A single phase step-down transformer has a high voltage primary winding and a low voltage secondary winding. The secondary winding is connected to a load impedance Z_2 . The impedance Z_2 when referred to the primary winding is denoted by Z_2' . Which of the following conditions is true?

- (A) $Z_2' = Z_2$
(B) $0.5Z_2 < Z_2' < Z_2$
(C) $Z_2' > Z_2$
(D) $Z_2' \leq 0.5Z_2$

Ans. C

Q.18 A square wave signal of frequency 20 kHz is passed through an ideal low-pass filter with cut-off frequency of 21 kHz. The output signal is a_____.

- (A) 20 kHz sine wave
(B) 20 kHz square wave
(C) 20 kHz triangular wave
(D) 20 kHz saw-tooth wave

Ans. A

Q.19 Given $x(t) = 4\sin(15\pi t) + 7\cos(4\pi t)$, where t is in seconds. The fundamental period of $x(t)$ is_____ seconds.

- (A) 15
(B) 60
(C) 30
(D) 2

Ans. D

Q.20 Among the following, the differential equations not representative of a linear dynamical system is/are_____.

(i) $\frac{d^2x}{dt^2} + 2t \frac{dx}{dt} + x(t) = u(t)$

(ii) $\left(\frac{dx}{dt}\right)^2 + 2 \frac{dx}{dt} + x(t) = u(t)$

(iii) $\frac{d^2x}{dt^2} + 2 \frac{dx}{dt} + x(t) = u(t)$

- (A) (i) and (ii) only
(B) (i) only
(C) (ii) only
(D) (ii) and (iii) only

[Engineering Mathematics, Differential Equations]

Ans. D

Q.21 A common gate amplifier represents a _____.

- (A) voltage controlled voltage source
- (B) current controlled current source
- (C) voltage controlled current source
- (D) current controlled voltage source

Ans. B

Q.22 In the circuit shown, the BJT has a β of 100. The base-emitter junction voltage is 0.65 V. The quiescent collector current, I_C is _____ mA.

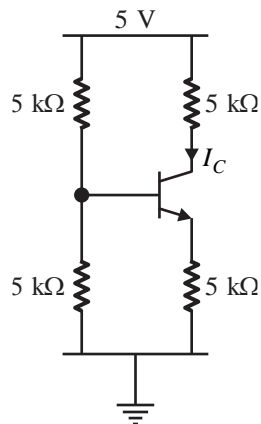

- (A) 0.365 (B) 0.435 (C) 0.625 (D) 0.862

Ans. A

Q.23 The maximum signal to quantization noise ratio (SQNR) for a 16-bit analog-to-digital converter is approximately _____ dB.

- (A) 48 (B) 68 (C) 88 (D) 98

Ans. D

Q.24 The Kelvin double bridge is used to measure _____ valued resistances and has _____ resistors in its construction.

- (A) Low; three-terminal (B) low; four-terminal
(C) High; three-terminal (D) High; four-terminal

Ans. B

Q.25 Active strain gauges are connected in a half-bridge configuration to measure strain in a cantilever element. When powered by a voltage source of 10 V, the voltage at the output of the bridge is 1 mV. If the gauge factor is 2.5, the strain in the cantilever element is _____ microstrain.

- (A) 40 (B) 80 (C) 20 (D) 160

Ans. B

Q.26 A glass pH electrode behaves linearly with an output change of 60 mV per unit change in pH. The measurement reference is set such that a solution of pH 6 produces an output of 60 mV. The pH of a solution that results in an output of -90 mV is _____.

- (A) 3.5 (B) 3 (C) 8 (D) 8.5

Ans. D

Q.27 An analog speech signal contains signals from 200 Hz to 2400 Hz. It is sampled at 6 kHz and quantized with 512 levels for pulse code modulation (PCM). The bit rate will be _____ kbps.

- (A) 16 (B) 48 (C) 19.2 (D) 54

Ans. D

Q.28 The slope efficiency of a laser diode is 0.5 W/A, and the output optical power at a current of 100 mA is 30 mW. Assuming piece-wise linear characteristics of the laser diode, the threshold current of the laser is _____ mA.

- (A) 0 (B) 20 (C) 40 (D) 60

Ans. C

Q.29 In a linear element, the measured current is $100 \text{ mA} \pm 2.5\%$ and the measured voltage is $5 \text{ V} \pm 5\%$. Which of the following options show(s) the consumed power?

- (A) $(500 \pm 37.5) \text{ mW}$ (B) $(500 \pm 12.5) \text{ mW}$
(C) $500 \text{ mW} \pm 7.5$ (D) $500 \text{ mW} \pm 2.5$

Ans. A, C

Q.30 Which of the following statements is/are correct for a thermocouple?

- (A) It is based on the Seebeck Effect.
(B) The change in resistance is measured.
(C) The voltage difference between the two junctions is linearly proportional to the temperature difference between the junctions.
(D) It is based on the concept of Joule Heating.

Ans. A, C

Q.31 A data set is given to be $[1, 2, 0, -1, -3, 1, 2, 0, 1]$.

The median of the data set is _____. (rounded off to the nearest integer)

[Engineering Mathematics, Probability]

Ans. 1 to 1

Q.32 The potential difference between nodes A and B in a circuit is $v_A - v_B = 5 \text{ V}$. The work done in moving a charge of 1 coulomb from point B to A is _____ J. (answer in integer)

Ans. 5 to 5

Q.33 In a series RL circuit shown in the figure, the current through the resistor lags the AC source voltage by 45° . Let $R = 100\pi \Omega$ and $L = 2 \text{ H}$.

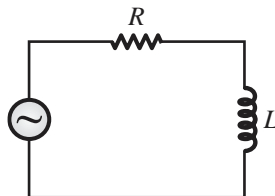

The frequency of the source is _____ Hz. (rounded off to the nearest integer)

Ans. 25 to 25

Q.34 In the circuit below the maximum value of v_{out} is _____ V. (rounded off to the nearest integer)

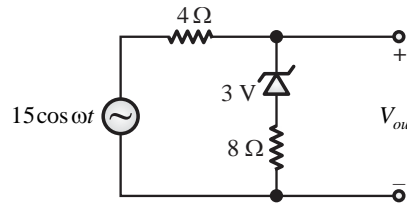

Ans. 11 to 11

Q.35 The minimum number of comparators required in a 6-bit flash analog-to-digital converter is _____. (answer in integer)

Ans. 63 to 63

Q.36 to Q.65 Carry Two Marks Each

Q.36 A box contains three apples and two oranges. Two fruits are removed randomly in succession. The probability that the first is an apple and the second is an orange is _____.

- (A) $\frac{3}{5}$ (B) $\frac{3}{20}$ (C) $\frac{3}{10}$ (D) $\frac{2}{5}$

[Engineering Mathematics, Probability]

Ans. C

Q.37 An electric field in free space is

$$\vec{E} = (2x + 5y + 6z)\hat{i} + (5x + 4y + 10z)\hat{j} + (6x + 10y + 2z)\hat{k} \text{ V/m}$$

The charge density is _____ C/m³. (ϵ_0 is the permittivity of free space)

- (A) $8\epsilon_0$ (B) $10\epsilon_0$ (C) $6\epsilon_0$ (D) $4\epsilon_0$

Ans. A

Q.38 A straight thin wire carrying a current of $I = 1 \text{ A}$ in the direction $\hat{n} = \frac{1}{\sqrt{6}}\hat{i} + \frac{2}{\sqrt{6}}\hat{j} + \frac{1}{\sqrt{6}}\hat{k}$ is placed inside a magnetic field of $\vec{B} = (2\hat{i} + 2\hat{k})T$.

The force per unit length on the wire is _____ N/m.

- (A) $2\sqrt{6}\hat{i} - 2\sqrt{6}\hat{k}$ (B) $\sqrt{\frac{3}{2}}\hat{i} - \sqrt{\frac{3}{4}}\hat{j} + \sqrt{\frac{3}{4}}\hat{k}$
 (C) $\frac{4}{\sqrt{6}}\hat{i} - \frac{4}{\sqrt{6}}\hat{k}$ (D) $\sqrt{\frac{3}{2}}\hat{i} + \sqrt{\frac{3}{4}}\hat{j} + \sqrt{\frac{3}{4}}\hat{k}$

Ans. C

Q.39 A two-port network has z-parameters $z_{11} = z_{22} = 10\Omega$ and $z_{12} = z_{21} = 5\Omega$.

The value of R_L such that maximum power is transferred to R_L is _____ Ω .

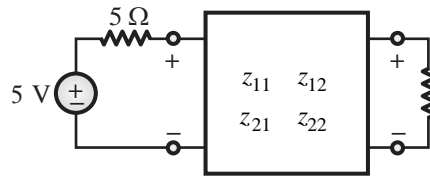

- (A) 5.67 (B) 8.33 (C) 10.33 (D) 25.67

Ans. B

Q.40 In the circuit shown below, the value of the output voltage V_0 is _____ V.

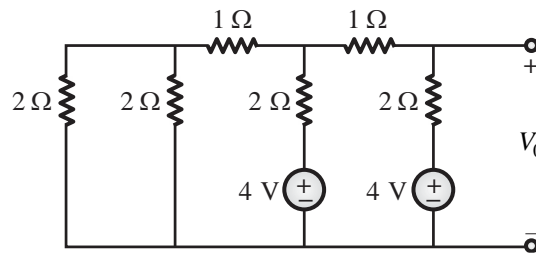

- (A) 2 (B) 3 (C) 4 (D) 8

Ans. B

Q.41 A signal $x(t)$ is shown below.

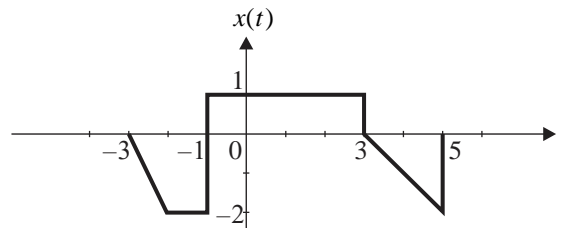

The plot of $y(t) = 1 - x(4 - t)$ is shown in _____.

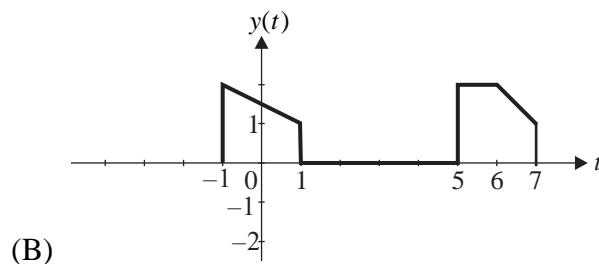
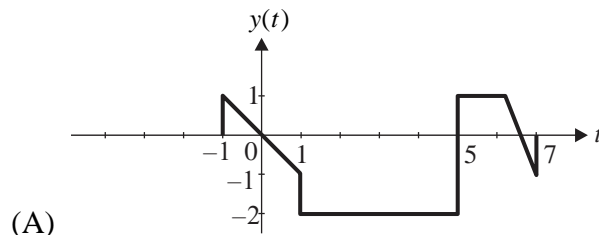

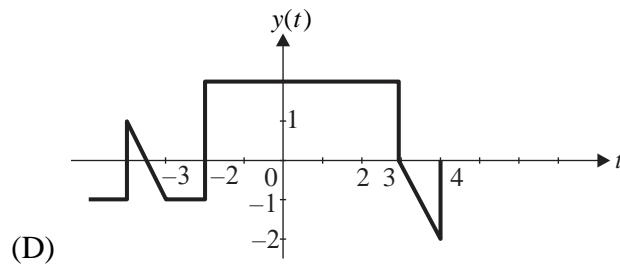
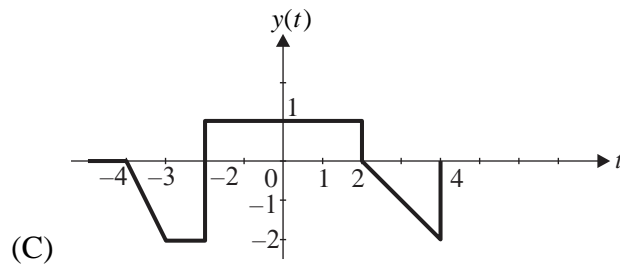

Ans. B

Q.42 In the table shown below, List-I are the system responses to input $x(t)$ and List II are the system properties. The correct matching is_____.

List I		List II	
(M)	$x^2(t)$	(I)	Linear and Time-invariant
(N)	$x(-t)$	(II)	Non-linear and Time-varying
(O)	$ x(3-t) $	(III)	Linear and Time-varying
(P)	$x(t-3)$	(IV)	Non-linear and Time-invariant

- (A) M-IV, N-III, O-II, P-I
 (B) M-II, N-I, O-IV, P-III
 (C) M-III, N-IV, O-II, P-I
 (D) M-I, N-IV, O-III, P-II

Ans. A

Q.43 Given two signals : $x(t) = u(t-2) - u(t-3)$ and $y(t) = e^{-4t}u(t)$.

If $z(t) = x(t) * y(t)$, then $Z(s)$ is_____.

- (A) $\frac{e^{-3s}[e^s - 1]}{s(s+4)}$ (B) $\frac{e^{-s}[e^{-3s} - 1]}{(s+3)(s+4)}$
 (C) $\frac{e^{-3s}[1 - e^s]}{(s+3)(s+4)}$ (D) $\frac{e^{-3s}[1 - e^s]}{s(s+4)}$

Ans. A

Q.44 A linear time invariant (LTI) system is described by :

$$\begin{bmatrix} \dot{x}_1 \\ \dot{x}_2 \end{bmatrix} = \begin{bmatrix} 0 & 1 \\ -10 & -7 \end{bmatrix} \begin{bmatrix} x_1 \\ x_2 \end{bmatrix} + \begin{bmatrix} 1 \\ 1 \end{bmatrix} u$$

$$y = [1 \quad 1] \begin{bmatrix} x_1 \\ x_2 \end{bmatrix}$$

The poles of the system are_____.

- (A) $-2, -5$ (B) $2, 5$ (C) $-2, 5$ (D) $2, -5$

Ans. A

Q.45 In the circuit shown below, R is $1\text{k}\Omega$ and R_f is $10\text{k}\Omega$. If V_{in} is 100 mV and the op-amps have supply voltages of $+15\text{ V}$, then V_{out} is_____ V.

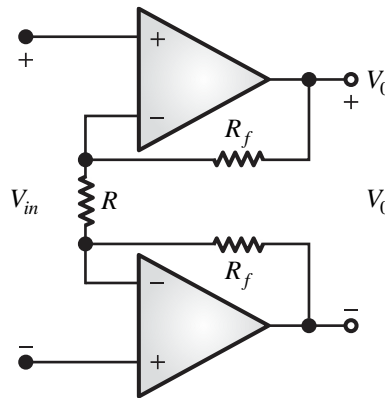

- (A) -15 (B) 15 (C) 2.1 (D) 1.1

Ans. C

Q.46 In the following active filter circuit with ideal op-amps, R is $1\text{k}\Omega$, C is $1\mu\text{F}$ and V_{in} has an amplitude of 1 V at 1000 rad/s .

Then amplitude of V_{out} is_____ V.

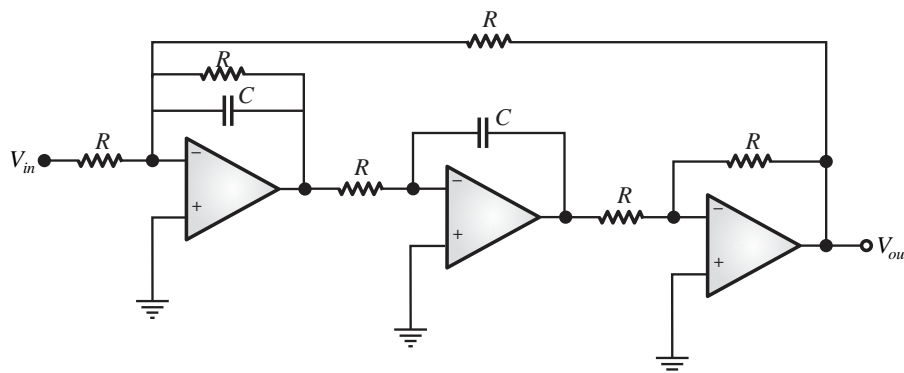

- (A) 0.5 (B) 0.707 (C) 1.0 (D) 1.414

Ans. C

Q.47 The initial state $Q_3Q_2Q_1Q_0$ in the digital circuit shown below is 1011 .

The new value of $Q_3Q_2Q_1Q_0$ after two rising edges of the clock (CLK) will be_____.

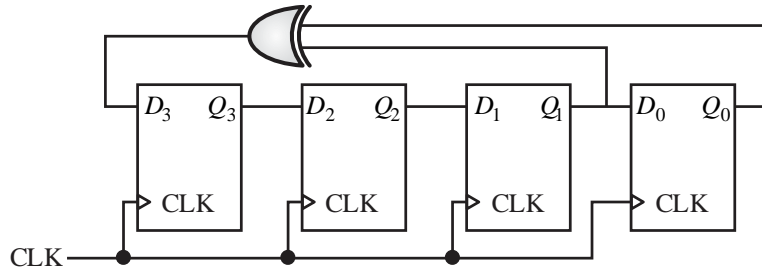

- (A) 1101 (B) 0101 (C) 1010 (D) 1011

Ans. C

Q.48 A closed Lissajous pattern observed on an oscilloscope in the X - Y mode has three horizontal tangencies and two vertical tangencies in steady state. If the signal- frequency on channel-X is 600 Hz, then the signal-frequency on channel-Y is_____Hz.

- (A) 300 (B) 400 (C) 600 (D) 900

Ans. B

Q.49 If the definition of SI unit 'X' is required to define SI unit 'Y', the dependency is indicated as $X \rightarrow Y$. A valid order of dependencies, as per present convention, is_____.

- (A) metre \rightarrow second \rightarrow kilogram \rightarrow kelvin
 (B) second \rightarrow metre \rightarrow kilogram \rightarrow kelvin
 (C) metre \rightarrow second \rightarrow kelvin \rightarrow kilogram
 (D) second \rightarrow kilogram \rightarrow kelvin \rightarrow metre

Ans. B

Q.50 A parallel plate capacitive displacement sensor has a plate area of 2 cm^2 . The air gap between the plates is decreased by 0.1 mm from an initial value of 0.5 mm The percentage change in the capacitance value is_____%.

(Assume permittivity as $\epsilon_0 = 8.854 \times 10^{-12} \text{ F/m}$)

- (A) 10.0 (B) 14.1 (C) 25.0 (D) 30.0

Ans. C

Q.51 The emitted radiant energy from a piece of metal was measured using a pyrometer. The temperature was calculated to be 1000°C , assuming a surface emissivity of 0.8. It was later found that the true surface emissivity was 0.7.

The actual temperature of the object is nearest to_____ $^\circ\text{C}$.

- (A) 1043 (B) 958 (C) 1033 (D) 967

Ans. A

Q.52 An amplitude modulated voltage signal $x(t)$ drives a load of 1Ω .

$$x(t) = K \cos(300\pi t) + L \cos(240\pi t) + L \cos(360\pi t)$$

If the efficiency is 60% and the carrier power is 50 W. the value of L is_____V.

- (A) 8.66 (B) 1.22 (C) 0.81 (D) 17.32

Ans. A

Q.53 Given $f(x, y) = x^2 - 2xy + y^2$

The complete contour of the equation $f(x, y) = 1$ is described by the options_____.

- (A) A line, $x - y = 1$
 (B) A circle with radius 1
 (C) An ellipse with length of major axis equal to 1
 (D) A line, $x - y = -1$

[Engineering Mathematics, Maxima & Minima]

Ans. A, D

Q.54 Given a differential equation $\frac{d^2x}{dt^2} + x = 0$ with $x(0) \neq 0$.

Which of the following statements is/are true?

- (A) $|x(t)|^2 + \left|\frac{dx(t)}{dt}\right|^2 = 0$ for all $t \geq 0$
 (B) $|x(t)|^2 + \left|\frac{dx(t)}{dt}\right|^2 = c$ for all $t \geq 0$, for some real constant $c > 0$
 (C) $|x(t)|^2 + \left|\frac{dx(t)}{dt}\right|^2 = e^{jt}$ for all $t \geq 0$
 (D) $|x(t)|^2 + \left|\frac{dx(t)}{dt}\right|^2 = \sin t$ for all $t \geq 0$

[Engineering Mathematics, Differential Equations]

Ans. B

Q.55 Which of the following functions represent(s) the output of the CMOS logic-gate shown in the circuit below?

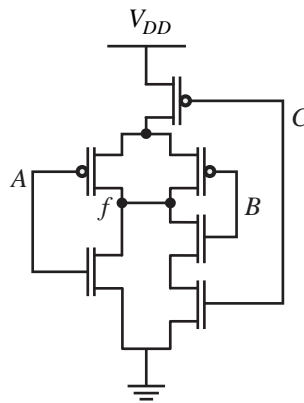

(A) $f = \bar{A} + \bar{B} \cdot \bar{C}$

(B) $f = \overline{A + BC}$

(C) $f = \bar{A} \cdot (\bar{B} + \bar{C})$

(D) $f = \overline{A \cdot (B + C)}$

Ans. B, C

Q.56 A 16-bit processor has 16-bit wide instructions and a few internal registers. Every 16-bit instruction is encoded in a fixed format with one operation code of 7 bits and up to three operands. The operand can be an internal register and each operand is encoded by 3 bits. All the internal registers can be specified in an instruction using three bits.

The correct statements) for this processor is/are _____.

(A) The processor has 16 internal registers.

(B) The processor can support 128 unique operation codes (Opcodes).

(C) The processor has up to 8 internal registers.

(D) The processor can support 512 unique operation codes (Opcodes).

Ans. B, C

Q.57 Let $f(t) = \begin{cases} 1, & t \in [0, 2] \\ -t + 3, & t \in [2, 3] \\ 0, & \text{otherwise} \end{cases}$

Then

$$\int_{-\infty}^{\infty} f(\tau) d\tau = \text{_____}. \text{ (rounded off to one decimal place)}$$

Ans. 2.4 to 2.6

Q.58 A single phase transformer has a rating of 10 kVA, 50 Hz, 1100 V/ 220 V. In an open circuit test with the high voltage side open, the following are obtained :

- Voltage applied to the low voltage winding = 220 V
- Measured power = 363 W
- Measured current = 2.75 A

Magnetizing reactance X_m referred to the high voltage winding is _____ Ω .

(rounded off to the nearest integer)

Ans. 2490 to 2510

Q.59 A linear time invariant (LTI) system has a transfer function

$$G(s) = \frac{10(s+1)}{s(s^2 + 2s + 5)}$$

The system is placed in unity negative feedback configuration.

For a unit ramp reference, the steady state error is _____.

(rounded off to two decimal places)

Ans. 0.49 to 0.51

Q.60 The system $G(s) = \frac{k}{(s+1)^4}$ has a gain margin of 20 dB. The value of K is _____. (rounded off to two decimal places)

Ans. 0.39 to 0.41

Q.61 In the phase-locked-loop circuit shown below, the output of the VCO is a digital square wave.

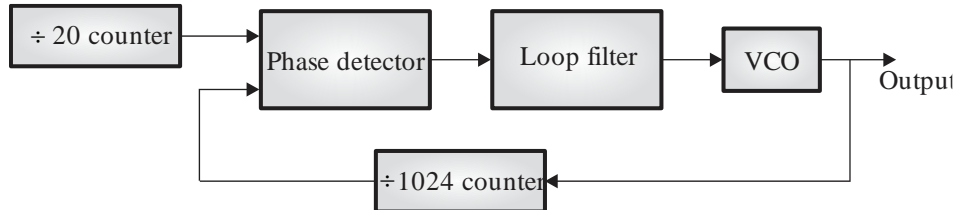

If the input is a square wave at 10 kHz, the steady state frequency of the output is _____ kHz. (rounded off to the nearest integer)

Ans. 512 to 512

Q.62 A digital counter increments its count every $0.1 \mu\text{s}$. The counter is used in an instrument to measure frequency. The counter is operated for one period of the input signal to the instrument to measure its frequency. The input signal is approximately at 100 kHz. The maximum error in the measured frequency is _____ kHz. (rounded off to the nearest integer)

Ans. 1 to 1

Q.63 A current carrying semiconductor of thickness 0.7 mm is placed in a transverse magnetic field. The measured Hall voltage is 0.9 mV and the current is 6 mA. If the Hall coefficient is $4 \times 10^{-4} \text{ m}^3/\text{s}$, the value of the incident magnetic field is _____ T. (rounded off to two decimal places)

Ans. 0.25 to 0.27

Q.64 For a fiber Bragg grating-based sensor, the shift in the Bragg wavelength gives information about the value of the measurand. For a Bragg wavelength of 1550 nm and effective index of 1.44, the grating period is _____ nm. (rounded off to two decimal places)

Ans. 537.00 to 539.00

Q.65 A photodiode has a responsivity 0.8 A/W. If the input optical power to the photodiode is 2 mW, the power delivered to a 50Ω load is _____ μW . (rounded off to the nearest integer)

Ans. 128 to 128

