

General Aptitude**Q.1 to Q.5 Carry One Mark Each**

Q.1 “He often _____ the numbers. False claims are not going to help. Honesty _____ trust”, said the manager. Choose the option with the correct order of words to fill the blanks.

- (A) exaggerates; engenders (B) excels; encourages
(C) aggravates; alleviates (D) diminishes; eliminates

Ans. A

Q.2 In the sequence of tiles shown below, the missing tile indicated by the question mark should be

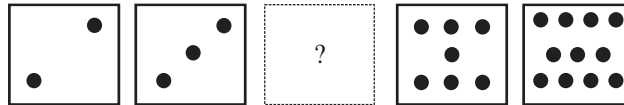

- (A)  (B) 
(C)  (D) 

Ans. B

Q.3 A school has 100 students distributed among 1st to 10th standards. Based on this, which one of the following statements is always correct ?

- (A) There are at least 10 students who belong to the same standard.
(B) There is at least one student in each standard.
(C) There are at most 10 students in 10th standard.
(D) The total number of students from 1st to 5th standards is at least 50.

Ans. A

Q.4 How many 3-digit numbers can be formed using three distinct single digit prime numbers?

- (A) 64 (B) 24
(C) 12 (D) 4

Ans. B

Q.5 In a group of students, 10 students like Mathematics, 12 students like English, 4 students like both Mathematics and English, and 6 students like neither Mathematics nor English. The number of students in the group is _____.

- (A) 18 (B) 20
(C) 24 (D) 32

Ans. C

Q.6 to Q.10 Carry Two Marks Each

Q.6 Charity : P :: Retaliation : Q

Choose the appropriate pair of words P and Q that fit the analogy.

- (A) P = Parsimonious; Q = Vengeful
(B) P = Altruistic; Q = Amicable
(C) P = Resentful; Q = Spiteful
(D) P = Magnanimous; Q = Vindictive

Ans. D

Q.7 A paper shown in Panel I is folded along the dashed lines (---) to construct a cube. The shaded regions shown in Panel I appear on the outer surface of the cube. Referring to cubes shown in Panel II, which one of the options is correct ?

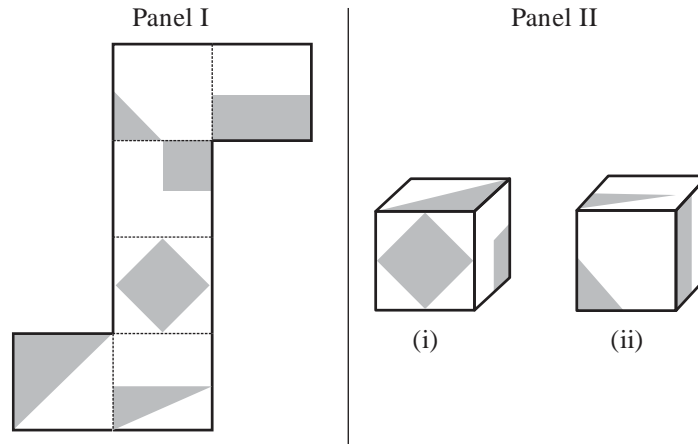

- (A) Only (i) can correspond to the unfolded cube in Panel I.
(B) Only (ii) can correspond to the unfolded cube in Panel I.
(C) Both (i) and (ii) can correspond to the unfolded cube in Panel I.
(D) Neither (i) nor (ii) can correspond to the unfolded cube in Panel I.

Ans. A

Q.8 Consider the cube shown below with its 8 corners labelled a, b, c, d, e, f, g, and h. The figure is representative. All corners are to be colored such that any two corners that are connected by an edge must be of different colors. The minimum number of colors required to achieve this is _____

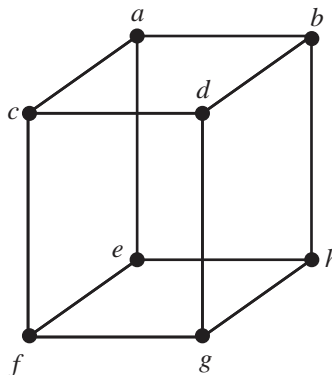

- (A) 8
(B) 4
(C) 3
(D) 2

Ans. D

- Q.9** Four hills H1, H2, H3, and H4 are present in an area. The following observations are made about them:
- Neither H2 nor H3 is the easternmost hill.
 - Neither H2 nor H3 is the westernmost hill.
 - Neither the easternmost hill nor the westernmost hill is the southernmost hill.
 - Two hills are located to the west of H2.
 - The southernmost hill has at least two hills to its east.

The southernmost hill is _____.

- (A) H1 (B) H2
(C) H3 (D) H4

Ans. C

- Q.10** As shown in the figure, circle C_1 with center O_1 and radius r_1 touches the $VWXY$ at points P and Q while circle C_2 with center O_2 and radius r_2 touches the square $VWXY$ at points R and S . The two circles touch each other at T .

Given : $r_1 = 1\text{cm}$ and $\overline{VY} = 4\text{cm}$, $r_2 =$ _____ cm

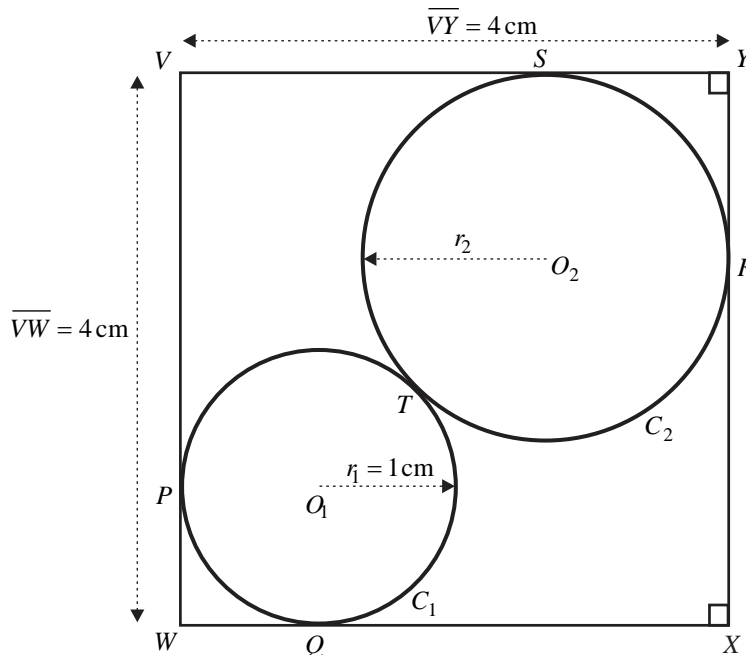

- (A) $4 - 3\sqrt{2}$ (B) $1 + 2\sqrt{2}$
(C) $7 - 4\sqrt{2}$ (D) $5 + 3\sqrt{2}$

Ans. C

Technical Section

Q.11 to Q.35 Carry One Mark Each

- Q.11** Which one of the following is NOT a type of chain conveyor ?
- (A) apron conveyor (B) bucket conveyor

(C) scraper conveyor

(D) screw conveyor

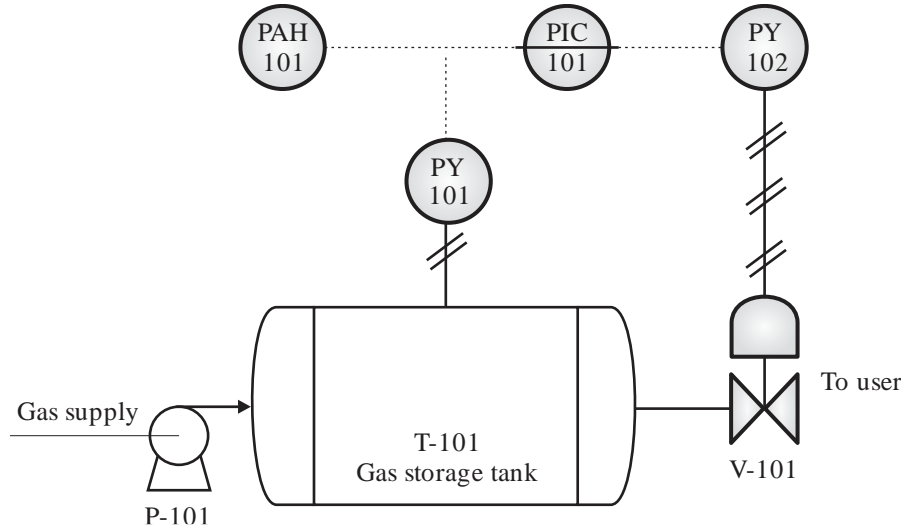
Ans. D**Q.12** In the P&ID shown below, which one of the following is the function of PAH in the process?

(A) to maintain a constant pressure in the vessel by throttling the pump outlet

(B) to alert when high pressure is detected in the tank

(C) to measure the average pressure in the vessel and display it locally

(D) to regulate the flow from the vessel to downstream users

Ans. B**Q.13** A body is placed inside a perfectly black enclosure and is allowed to reach thermal equilibrium. According to the Kirchhoff's identity, which one of the following is equal to the emissivity of the body at a given wavelength?

(A) absorptivity of the body at the same wavelength

(B) reflectivity of the body at the same wavelength

(C) Stefan-Boltzmann constant

(D) zero

Ans. A**Q.14** Which one of the following ratios does Grashof number represent?

(A) buoyancy force to inertia force

(B) buoyancy force to viscous force

(C) viscous force to capillary force

(D) viscous force to inertia force

Ans. B**Q.15** Consider a closed system of one mole of an ideal gas undergoing a polytropic process. The process follows $PV^n = \text{constant}$, where P is the pressure, V is the volume and n is a constant. If the process is isobaric, which one of the following is the value of n ?

(A) 0



- (B) 1
(C) ∞
(D) the ratio of specific heat capacity at constant pressure to specific heat capacity at constant volume

Ans. A

Q.16 According to the phase rule, which one of the following is the number of degrees of freedom for pure water at its triple point ?

- (A) -3 (B) 0
(C) 1 (D) 3

Ans. B

Q.17 An irreversible chemical reaction occurs on a porous catalyst. All the pores are of same size. In strong pore diffusion regime, the observed activation energy is 120 kJ mol^{-1} . The activation energy of diffusion is 10 kJ mol^{-1} . Assuming Arrhenius temperature dependency for both reaction and diffusion, which one of the following is the true activation energy (in kJ mol^{-1}) of the reaction ?

- (A) 65 (B) 110
(C) 130 (D) 230

Ans. D

Q.18 In a traditional continuous Kraft (Sulfate) pulping process, consider the following major steps: Bleaching (BL), Chipping (CH), Debarking (DE), Digestion (DI), and Pulp Washing (WA). Which one of the following is the CORRECT sequence of steps for this process?

- (A) DE \rightarrow BL \rightarrow WA \rightarrow DI \rightarrow CH (B) DE \rightarrow CH \rightarrow DI \rightarrow WA \rightarrow BL
(C) DE \rightarrow CH \rightarrow WA \rightarrow DI \rightarrow BL (D) DE \rightarrow BL \rightarrow WA \rightarrow CH \rightarrow DI

Ans. B

Q.19 For an irreversible reaction containing inerts in the feed, single-pass conversion in a reactor is 70%. Which one of the following statements is CORRECT?

- (A) Recycle eliminates the need for a purge stream.
(B) Recycle reduces the concentration of inerts in the system.
(C) Recycle increases the overall conversion.
(D) Recycle decreases the overall conversion.

Ans. C

Q.20 A binary mixture of butane and butadiene is to be separated in an extractive distillation using furfural. Furfural lowers the activity of butadiene more than it does for butane. Consider the distillation sequence shown in the figure.

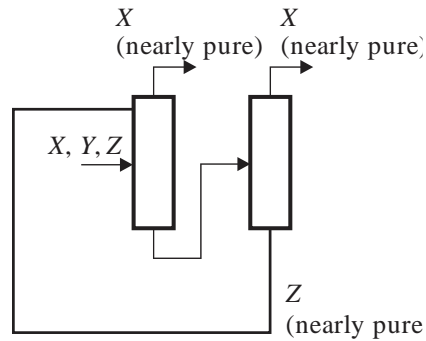

Match the component labels in Group I with chemical species in Group II.

Group I		Group II	
P.	Component X	1.	Butane
Q.	Component Y	2.	Butadiene
R.	Component Z	3.	Furfural

- (A) P-1, Q-2, R-3
(C) P-2, Q-1, R-3

- (B) P-1, Q-3, R-2
(D) P-2, Q-3, R-1

Ans. A

Q.21 A two-dimensional temperature profile is given as $T = 2x^2 + 3xy + y^2$. If i and j are the unit vectors along x and y direction, respectively. Which one of the following is the directional derivative of T at the location $x = 2, y = 2$.

- (A) $8\hat{i} + 12\hat{j}$ (B) $14\hat{i} + 10\hat{j}$
(C) $8\hat{i} - 12\hat{j}$ (D) $14\hat{i} - 10\hat{j}$

Ans. B

Q.22 Which one of the following is the value of $\lim_{x \rightarrow \infty} \frac{e^x - x - 1}{\cos x - 1}$?

- (A) -1 (B) 0
(C) 1 (D) ∞

Ans. A

Q.23 Which one of the following is the pair of eigenvalues of the matrix $\begin{bmatrix} -3 & 4 \\ 4 & 3 \end{bmatrix}$?

- (A) -7, 7 (B) -5, 5
(C) -4, 3 (D) -3, 4

Ans. B

Q.24 Which one of the following is produced by catalytic reforming of straight run gasoline and naphtha?

- (A) diesel oil (B) furnace oil
(C) high octane gasoline (D) kerosene

Ans. C



Q.25 A process exhibits an inverse response to a step input. Which of the following statements is/are necessarily TRUE about the process ?

- (A) Its transfer function has a positive zero.
- (B) Its transfer function has a negative zero.
- (C) The initial direction of the step response is opposite to the final steady state value.
- (D) The system is unstable due to a zero in the right half of the s-plane.

Ans. A, C

Q.26 Urea has its major use as a solid fertilizer for nitrogen fixation. Which of the following is/are other application(s) of urea?

- (A) manufacturing of resins and plastics
- (B) melamine production
- (C) muriatic acid production
- (D) sulfamic acid production

Ans. A, B, D

Q.27 Which of the following statements regarding the heat of reaction is/are CORRECT ?

- (A) For endothermic reaction, it is positive.
- (B) For exothermic reaction, it is negative.
- (C) For exothermic reaction, it is positive.
- (D) It is the enthalpy change for a process in which stoichiometric quantities of reactants, at a temperature and pressure, react completely in a single reaction to form products at the same temperature and pressure.

Ans. A, B, D

Q.28 In which of the following condition(s), Bernoulli's equation is applicable ?

- (A) incompressible flow
- (B) inviscid flow
- (C) unsteady flow
- (D) flow along a streamline

Ans. A, B, D

Q.29 Which of the following methods for calculating profitability does/do NOT consider the time value of money ?

- (A) rate of return on investment
- (B) discounted cash flow rate of return
- (C) payback period
- (D) net present worth

Ans. A, C

Q.30 Consider two successive screen sizes in the Tyler standard screen scale, viz. 150 meshes per inch and 200 meshes per inch. Their linear sizes of the openings are L_{150} and L_{200} respectively. If the value of L_{200} is 2.9×10^{-3} inch, then the value of L_{150} (in inch) is _____ $\times 10^{-3}$ (Rounded off to one decimal place).

Ans. 4.0 to 4.2

Q.31 Consider a homogeneous gas phase reaction, $A+2B \rightarrow 2C+3D$, occurring at constant temperature and pressure in a varying volume batch reactor. The vessel is initially charged with 50 moles of A and 150

moles of B. The gases behave ideally. For complete conversion of A, the ratio of the final volume to the initial volume is _____ (rounded off to one decimal place).

Ans. 1.4 to 1.6

Q.32 Water is discharged from vertical side of a tank through a circular orifice of diameter 2 cm under laminar flow conditions. The water surface in the tank is maintained at constant level above the center of the orifice. If the fluid jet has a diameter of 1.6 cm at its vena contracta, then the coefficient of contraction is _____ (rounded off to two decimal places).

Ans. 0.63 to 0.65

Q.33 Consider a non-reactive binary mixture of two ideal gases A and B in an isothermal horizontal closed tube. Due to the concentration difference at the two ends of the tube, equimolar counterdiffusion occurs along the axial direction. No concentration gradients exist in the radial direction. The profile for partial pressure of component A (p_A) as a function of axial distance z is shown in the figure. The partial pressure of component B (p_B) approaches zero at $z = 0.8\text{m}$. At a location $z = z_1$ the partial pressures of the components A and B are equal. The value of z_1 (in m) is _____. (Rounded off to two decimal places)

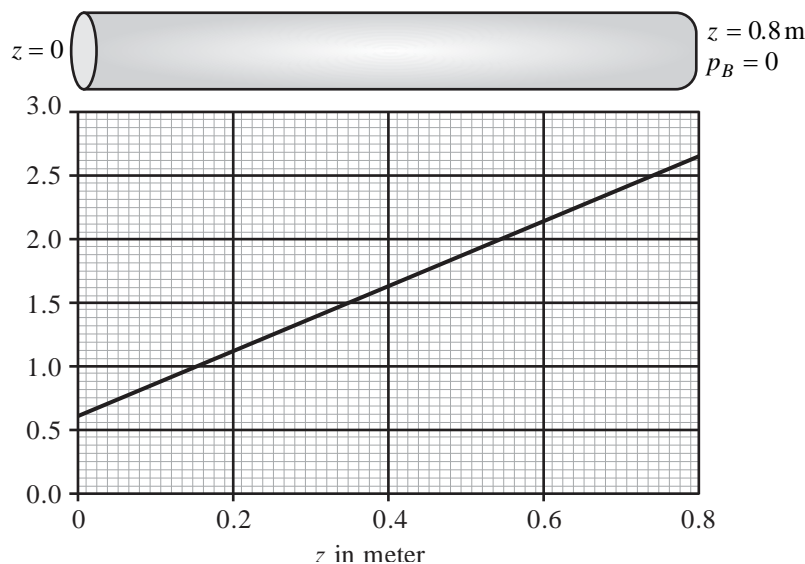

Ans. 0.27 to 0.29

Q.34 An experiment is performed by rolling an unbiased die once. Events A and B are defined as follows:

Event A : The outcome of the rolled die is a prime number.

Event B : The outcome of the rolled die is an odd number less than 4.

The conditional probability of A given B, denoted by $P(A|B)$, is _____ (rounded off to one decimal place).

Ans. 0.5 to 0.5

Q.35 Using single step trapezoidal rule, the value of

$$\int_0^{0.5} (1 + 16x - 20x^2) dx$$

is _____ (rounded off to two decimal places).

Ans. 1.24 to 1.26

Q.36 to Q.65 Carry Two Marks Each

Q.36 K value is defined as the ratio of mole fraction of a component in the vapor phase to that in the liquid phase. The K values of propane and iso-butane at 293 K are given in the table.

Pressure (kPa)	K Values	
	Propane	iso - Butane
1100	1.8	0.85
1200	1.6	0.75
1300	1.4	0.65
1400	1.25	0.5
1500	1.1	0.45

Which one of the following is closest to the bubble point pressure (in kPa) of an equimolar mixture of propane and iso-butane at 293 K ?

- (A) 1110 (B) 1190
(C) 1310 (D) 1390

Ans. C

Q.37 Consider a flow with the following velocity field

$$\vec{V} = (x + y)\hat{i} + (y + z)\hat{j} + (z + x)\hat{k}$$

where \hat{i} , \hat{j} and \hat{k} are the unit vectors in the x , y and z directions, respectively. Which one of the following is CORRECT?

- (A) The flow is incompressible and irrotational.
(B) The flow is incompressible and rotational.
(C) The flow is compressible and rotational.
(D) The flow is compressible and irrotational.

Ans. C

Q.38 Vapor pressure of water at various temperature is given in the table.

Temperature (in K)	284	289	294	299	310
Vapor pressure of water (in kPa)	1.28	1.80	2.50	3.40	6.40

An air and water vapor mixture at 100 kPa with a relative humidity of 20% has a dry-bulb temperature of 310 K. Assume latent heat of vaporization for water is 44 kJ mol^{-1} and specific heat capacity of the air and water vapor mixture is $0.035 \text{ kJ mol}^{-1} \text{ K}^{-1}$. Which one of the following is the closest to its wet-bulb temperature (in K) ?

- (A) 284 (B) 294
(C) 310 (D) 321

**Ans. B**

Q.39 A volatile organic compound (VOC) is to be adsorbed from air onto a bed of activated carbon. The equilibrium capacity of activated carbon at the feed conditions is 0.4 grams VOC per gram of activated carbon. The column contains 4 grams of activated carbon per cm² of cross-section. The feed rate into the adsorber column is 0.2 grams VOC m⁻²h⁻¹. Breakthrough time is defined as the time at which the concentration at the exit of the bed (c) reaches a value of $0.05c_0$, where c_0 is the concentration of VOC in the feed. The breakthrough time for the bed is 2.1 h. The area under c/c_0 curve between the initial and breakthrough times is 0.1 h. Which one of the following is the fraction of unused bed at breakthrough ?

- (A) 0 (B) 0.25
(C) 0.50 (D) 0.75

Ans. D

Q.40 Consider the following complex numbers

$$z_1 = r_1(\cos \theta_1 + i \sin \theta_1)$$

$$z_2 = r_2(\cos \theta_2 + i \sin \theta_2)$$

Where r_1, r_2 are real numbers $0 \leq \theta_1 \leq \frac{\pi}{2}, 0 \leq \theta_2 \leq \frac{\pi}{2}$, and $i = \sqrt{-1}$

If $|z_1 + z_2| = |z_1| + |z_2|$, which one of the following conditions is necessarily CORRECT ?

- (A) $\theta_1 = 0, \theta_2 = \frac{\pi}{2}$
(B) $\theta_1 = \frac{\pi}{2}, \theta_2 = 0$
(C) $r_1 = r_2$
(D) $\theta_1 = \theta_2$

Ans. D

Q.41 Consider the following curve in polar coordinates.

$$r = 2 - 2 \sin \theta$$

Which one of the following is the area enclosed by the curve for $0 \leq \theta \leq 2\pi$?

- (A) 3π (B) 4π
(C) 5π (D) 6π

Ans. D

Q.42 Consider the following homogeneous isothermal liquid-phase parallel reactions carried out in three reactor configurations (having identical volumes and same operating temperatures), as shown in the figure.

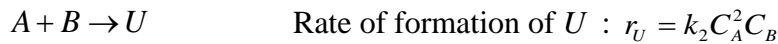
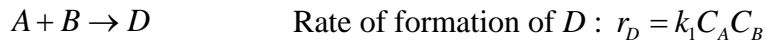

where D is the desired product and U is the undesired product. The inlet concentrations of A and B are the same in all three configurations ($C_{A0} = C_{B0} = 1 \text{ mol}^{-1}$). The total molar feed flow rate of A (F_{A0}) and that of B (F_{B0}) are the same in all three configurations ($F_{A0} = F_{B0} = 10 \text{ molmin}^{-1}$). In configuration III, F_{B0} is equally distributed among all the inlets. Assuming plug flow behavior, at steady state, which one of the following statements is CORRECT ?

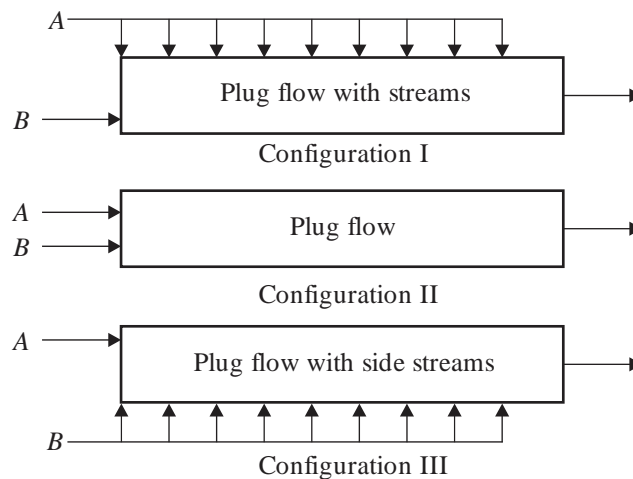

- (A) Configuration I and Configuration III give the same selectivity of the desired product.
 (B) Configuration I gives the highest selectivity of the desired product.
 (C) Configuration II gives the highest selectivity of the desired product.
 (D) Configuration III gives the highest selectivity of the desired product.

Ans. B

Q.43 The reaction rate constants of two reactions follow Arrhenius' law. The activation energies of Reaction 1 and Reaction 2 are E_1 and E_2 , respectively and $E_1 < E_2$. Assuming same value for the frequency factor for both the reactions, which one of the following statements is correct ?

- (A) Reaction 1 and Reaction 2 are less temperature sensitive at lower temperature than at higher temperature.
 (B) Reaction 1 and Reaction 2 have the same temperature sensitivity at all temperatures.

- (C) Reaction 1 is more temperature sensitive than Reaction 2 at all temperatures.
(D) Reaction 2 is more temperature sensitive than Reaction 1 at all temperatures.

Ans. D

Q.44 A control valve with hyperbolic characteristics has a turndown ratio (ratio of maximum flow to minimum controllable flow) of 50. The flow rate through the valve at 70% open is $5\text{ m}^2\text{ s}^{-1}$. Assuming constant fluid density and pressure drop across the valve, which one of the following is the flow rate (in $\text{m}^3\text{ s}^{-1}$) through the valve at 30% open ?

- (A) 1.1 (B) 2.2
(C) 3.3 (D) 4.4

Ans. B

Q.45 The gross energy requirement, to reduce a very large feed of coal to such a size that 80% of the product passes through a $100\ \mu\text{m}$ screen, is 13 kWh per ton of feed. In a process, 250 tons h^{-1} of coal is crushed. The range of feed sizes is such that 80% of the feed passes through an opening of 100 mm. The product size range is to be such that 80% of the product passes through an opening of 25 mm. According to the Bond's law, which one of the following is the power consumption (in kW) ?

- (A) 12.8 (B) 25.7
(C) 51.4 (D) 102.7

Ans. D

Q.46 In a certain project, 15% of the total investment is the working capital. The minimum acceptable rate of return is 4.95% and the period of evaluation is 15 years. Which one of the following is the maximum acceptable project payback period (in years) ?

- (A) 5 (B) 8
(C) 12 (D) 15

Ans. B

Q.47 A continuous distillation column is used to separate an equimolar mixture of diethylamine (DEA) and methanol. The feed enters the column as saturated liquid at a flow rate of 30 mols^{-1} . It is desired to obtain 92 mol% DEA as distillate. The rate of withdrawal of the distillate from the column is 10 mols^{-1} . The equilibrium curve for the conditions in the column is given below. The latent heat of vaporization of the reboiler contents is 35 kJ mol^{-1} . Neglect heat loss to the surroundings and assume constant molal overflow. Which one of the following is the minimum reboiler heat duty (in kW)?

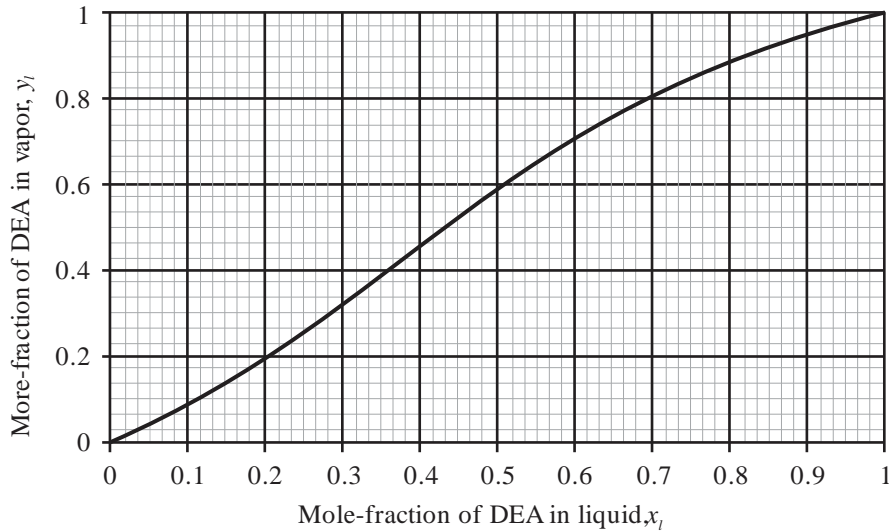

- (A) 350 (B) 700
(C) 1120 (D) 1470

Ans. D

Q.48 A gas stream with 2.01 mol % ammonia is to be scrubbed in a counter-current isothermal packed bed absorber using pure water to reduce its concentration to 0.01 mol %. Assume that dilute conditions apply, operating line is linear and the mass transfer coefficients are constant throughout the column. The liquid and the gas flows inside the absorber (in $\text{kmol m}^{-2}\text{h}^{-1}$) are 1000 and 200 respectively. The equilibrium relationship is $y = 0.9x$, where, y is the mole - fraction of ammonia in the gas phase and x is that in the liquid. Under these conditions, the height of overall gas transfer unit (H_{tOG}) is 0.8 m and the number of overall gas transfer units (N_{tOG}) is given by the following integral

$$N_{tOG} = \int_{y_1}^{y_2} \frac{dy}{y - y^*}$$

The integration is performed between the two ends of the column, and y^* is the equilibrium mole fraction in the gas phase, corresponding to the composition of the liquid at corresponding location. Which one of the following is the minimum length of the packing (in m) necessary to achieve the desired scrubbing ?

- (A) 4.2 (B) 5.0
(C) 6.2 (D) 7.7

Ans. B

Q.49 Laboratory filtration is conducted at constant pressure drop of 200 kPa on a slurry of CaCO_3 in water at room temperature. The time taken to collect filtrate is shown in the table.

Filtrate volume collected (in m^3)	Time (in s)
--	-------------



1×10^{-3}	40
2×10^{-3}	100

The filter area is 0.05^2 and viscosity of filtrate is 10^{-3} Pa.s. Which one of the following is the filter medium resistance (in m^{-1})?

- (A) 3×10^{-11} (B) 3×10^{-8}
(C) 3×10^8 (D) 3×10^{11}

Ans. D

Q.50 Consider three identical non-interacting first order processes in series, each having unit gain and a time constant of 2 min. Tuning of proportional controller using closed loop Ziegler-Nichols technique is considered. Which one of the following is the ultimate period of sustained cycling (in min per cycle)?

- (A) $4\sqrt{3}\pi$ (B) $\frac{\sqrt{3}\pi}{4}$
(C) $\frac{4\pi}{\sqrt{3}}$ (D) $\frac{\pi}{4\sqrt{3}}$

Ans. C

Q.51 A thermometer initially at a steady temperature of 30°C is inserted in a water bath maintained at 90°C . The initial rate of the thermometer is 2°C s^{-1} . Assuming first order behavior, the thermometer reading (in $^\circ\text{C}$) after one minute is _____ (rounded off to one decimal place).

Ans. 81.0 to 83.0

Q.52 In a double pipe cocurrent heat exchanger, operating at steady state, oil (specific heat capacity = $2100 \text{ J kg}^{-1} \text{ C}^{-1}$) entering at 7 kg s^{-1} at 100°C is used to heat water (specific heat capacity = $4200 \text{ J kg}^{-1} \text{ C}^{-1}$) flowing at 3.5 kg s^{-1} from 20°C to 50°C . If the overall heat transfer coefficient is $291 \text{ W m}^{-2} \text{ C}^{-1}$, the required heat transfer area (in m^2) is _____ (Rounded off to one decimal place)

Ans. 34.5 to 35.5

Q.53 In a double pipe cocurrent heat exchanger, operating at steady state, oil (specific heat capacity = $2100 \text{ J kg}^{-1} \text{ C}^{-1}$) entering at 7 kg s^{-1} at 100°C is used to heat water (specific heat capacity = $4200 \text{ J kg}^{-1} \text{ C}^{-1}$) flowing at 3.5 kg s^{-1} from 20°C to 50°C . If the overall heat transfer coefficient is $291 \text{ W m}^{-2} \text{ C}^{-1}$, the required heat transfer area (in m^2) is _____ (Rounded off to one decimal place)

Ans. 15.5 to 16.5

Q.54 Methanol is formed by the following gas phase homogeneous reaction :

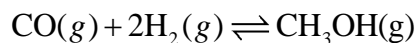

The standard Gibbs free energies of formation at 298 K for CO and CH₃OH are -137 kJ mol⁻¹ and -162 kJ mol⁻¹, respectively. The value of universal gas constant is 8.314 J mol⁻¹ K⁻¹. The equilibrium constant for the given reaction at 298 K is _____ × 10⁴ (Rounded off to one decimal place)

Ans. 2.3 to 2.5

Q.55 A first-order homogeneous liquid-phase reaction (A → B) occurs in an adiabatic, ideal mixed flow reactor operating at steady state. The volumetric flow rate of the feed is 4 L min⁻¹ and volume of the reactor is 20 L. At the reactor temperature of 500 K, the reaction rate constant is 1 min⁻¹, and heat of reaction is -20 kcal mol⁻¹. The average heat capacity of the feed as well as the reaction mixture in the temperature range of interest is 0.3 kcal mol⁻¹ K⁻¹

At the inlet, the feed temperature (in K) is _____ (rounded off to one decimal place).

Ans. 443.0 to 446.0

Q.56 A first order homogeneous liquid - phase reaction (A → B) occurs in a non-ideal isothermal reactor operating at steady state. The variance (σ²) of residence time distribution (RTD) from a pulse tracer experiment is 4 min². The volumetric flow rate of the feed is 5 L min⁻¹ and volume of the reactor is 25 L. The reaction rate constant is 0.4 min⁻¹. Based on the tanks in series model, the conversion (in %) is _____ (rounded off to one decimal place).

Ans. 82.0 to 82.6

Q.57 A feed containing 10 mol % propylene, 15 mol % ammonia and rest air is charged into a reactor to produce acrylonitrile (C₃H₃N) according to the following reaction.

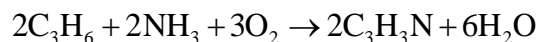

Assume, air contains 80 mol % N₂ and 20 mol % O₂

If the conversion of the limiting reactant is 30%, the composition of C₃H₃N (in mol%) in the product stream is _____ (Round off to two decimal places).

Ans. 2.90 to 3.00

Q.58 A gas mixture of 50 wt. % argon and 50 wt. % helium flowing through a horizontal tube of uniform diameter at a rate of 1 kg s⁻¹ is heated from 300 K to 400 K at 1 bar. Neglect shaft work, and changes in kinetic as well as potential energies between the inlet and the outlet. Assume the mixture exhibits ideal gas behavior. The specific enthalpies of the components are given in the following table.

Component	Specific enthalpy (kJ kg ⁻¹)
-----------	--

	at 300 K	At 400 K
Argon	348	400
Helium	1574	2092

At steady state, the heat input required (in kW) is _____ (rounded off to the nearest integer).

Ans. 285 to 285

Q.59 When a cylindrical capillary glass tube, open at both ends, is vertically inserted in a pool of water, the water level in the tube rises to 7 cm relative to the water level outside the tube. Consider that the surface tension of water is 0.07 Nm^{-1} and that the contact angle of water on glass is 0° . The density of water is 1000 kg m^{-3} , and the local acceleration due to gravity is 10 ms^{-2} . The diameter of the capillary tube (in μm) is _____ (Rounded off to the nearest integer).

Ans. 400 to 400

Q.60 Consider a two-dimensional, steady, laminar flow of an incompressible fluid with zero pressure gradient, over a thin horizontal flat plate of length 2 m. The free stream velocity is 1 ms^{-1} . A boundary layer thickness of 1 mm is observed at a distance of 0.25 m from the leading edge of the plate. At 1 m from the leading edge, the boundary layer thickness (in mm) is _____ (rounded off to the nearest integer).

Ans. 2 to 2

Q.61 The flooding velocity curves for two different structured packings are shown in the figure. The ratio of mass velocities of liquid (G_x) to that of the gas (G_y) is 1.27. The density of the liquid (ρ_x) is 1200 kg m^{-3} and that of the gas (ρ_y) is 1.2 kg m^{-3} . For both the packings, the allowable superficial vapor velocity is 60% of flooding velocity ($u_{0,F}$). The ratio of allowable mass velocity of the vapor in packing P to that packing Q is _____ (Rounded off to one decimal place)

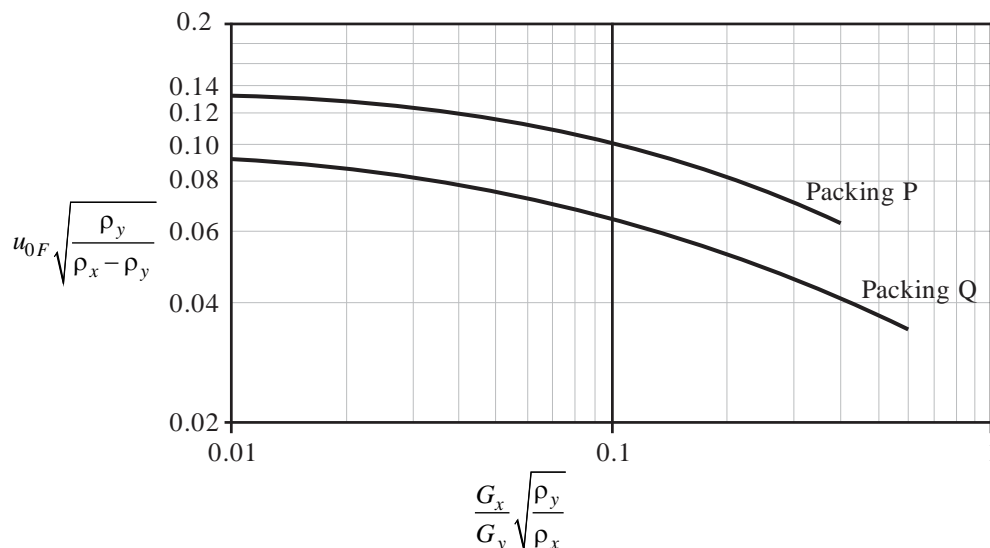

Ans. 1.4 to 1.6

Q.62 Consider a differential equation :

$$x^2 \frac{d^2 y}{dx^2} + 3 \frac{dy}{dx} - 3y = 0$$

$$\left. \begin{array}{l} y = 3 \\ \frac{dy}{dx} = -5 \end{array} \right\} \text{at } x = 1$$

The value of y at $x = 2$ is _____ (rounded off to two decimal places).

Ans. 2.24 to 2.26

Q.63 The data given in the table are fitted to the equation $y = mx$ using the method of least squares. The value of m is _____ (rounded off to one decimal place).

x	1	2	3	4
y	2	6	7	10

Ans. 2.49 to 2.51

Q.64 Cyclohexane (C_6H_{12}) is produced from benzene (C_6H_6) and hydrogen (H_2) according to the following reaction.

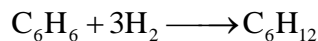

Consider the process flow diagram shown in the figure.

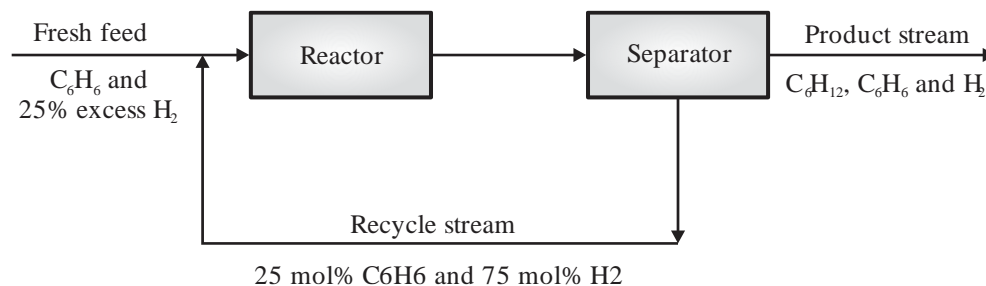

In this process, the overall and single-pass conversions are 90% and 25%, respectively. The recycle stream contains 25 mol % C_6H_6 and 75 mol % C_6H_6 . If the fresh feed contains 25% excess H_2 , at steady state, the ratio of the molar flow rate of recycle stream to that of the fresh feed is _____. (rounded off to one decimal place).

Ans. 2.1 to 2.3

Q.65 The velocity profile for a fully developed laminar flow of an incompressible Newtonian fluid, at steady state, through a horizontal infinitely wide and long slit of gap 0.01 m is given by the following equation.

$$u(y) = 7.5 - 3 \times 10^5 y^2$$



Where y is the vertical distance measured from the center of the slit. The average velocity of the fluid (in m s^{-1}) is_____. (rounded off to the nearest integer).

Ans. 5 to 5

